

國立中山大學99學年度碩士班招生考試試題

科目：電子學【通訊聯招碩士班甲組、電機系碩士班甲組、乙組、戊組、通訊所碩士班乙組】

- (15%) Calculate the built-in voltage of a junction in which the p and n regions are doped with 10^{15} atoms/cm³ and 10^{16} atoms/cm³, respectively. Assume $n_i \approx 10^{10}$ /cm³. With no external voltage applied, (i) (6%) what is the width of the depletion region, and (ii) (3%) how far does it extend into the p and n regions? If the cross-sectional area of the junction is $100 \mu\text{m}^2$, (iii) (3%) find the magnitude of the charge stored on either side of the junction, and (iv) (3%) calculate the junction capacitance C_j .
- (15%) The NMOS and PMOS transistors in the circuit of Figure 1 are matched with $k'_n(W_n/L_n) = k'_p(W_p/L_p) = 1 \text{ mA/V}^2$ and $V_{tn} = -V_{tp} = 0.7 \text{ V}$. (where k' is the process transconductance parameter, W/L is the ratio of the channel width to the channel length, V_t is the threshold voltage). Assuming process-technology parameter $\lambda = 0$ for both devices (neglect the effect of channel-length modulation), find the drain currents i_{DN} and i_{DP} and the voltage v_O for $v_I = 0 \text{ V}$, $+2.5 \text{ V}$, and -2.5 V .

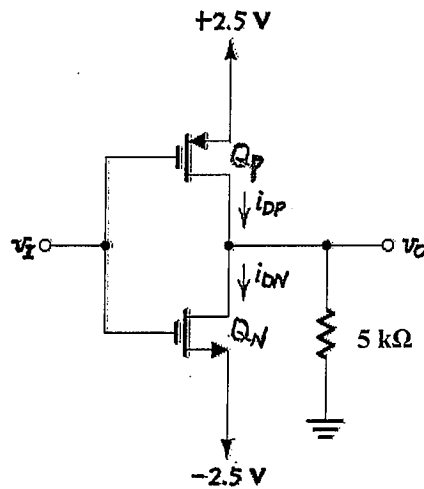

Figure 1

- (20%) To analyze the circuit in Figure 2, (i) (15%) to determine the voltages at all nodes (A, B, C, D, and E) and the currents through all branches (I_{B1} , I_{C1} , I_{E1} , I_{B2} , I_{C2} and I_{E2}), (ii) (5%) find the total current drawn from the power supply. Hence find the power dissipated in the circuit.

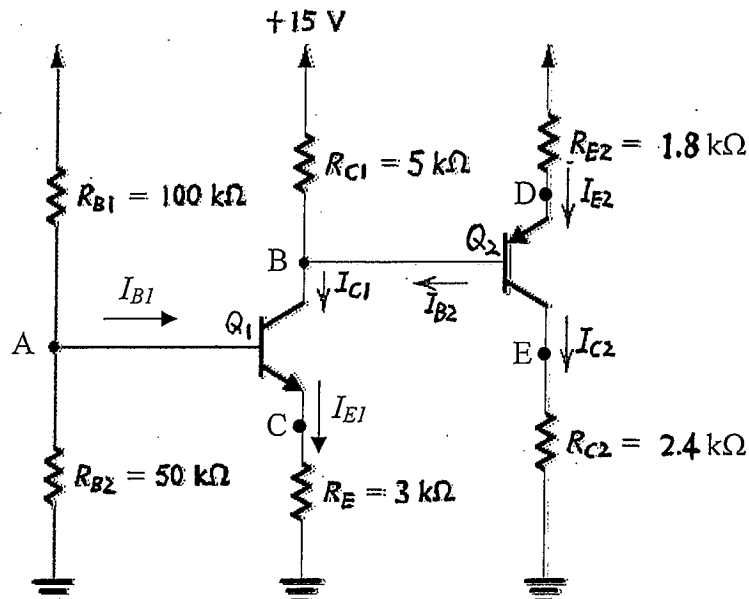

Figure 2

國立中山大學 99 學年度 碩士班 招生 考試 試題

科目：電子學【通訊聯招碩士班甲組、電機系碩士班甲組、乙組、戊組、通訊所碩士班乙組】

4. (15%) To analyze the instrumentation amplifier circuit shown in Figure 3, (i) (5%) to determine v_o as a function of v_1 and v_2 , (ii) (5%) to determine the differential gain $[v_o/(v_2 - v_1)]$ and (iii) (5%) to find the input resistance.

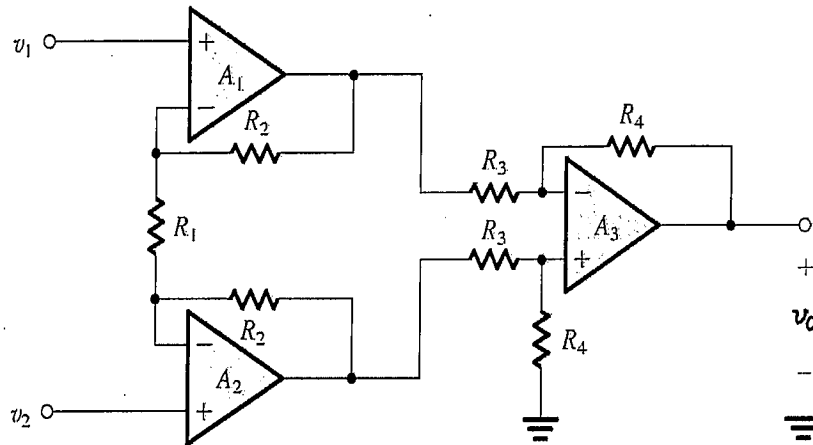

Figure 3

5. (20%) The differential amplifier in Figure 4 uses transistors with $\beta = 100$. Evaluate the following: (i) (5%) The input differential resistance R_{id} . (ii) (5%) The overall differential voltage gain v_o/v_{sig} (neglect the effect of r_o). (iii) (5%) The worst-case common-mode gain if the two collector resistances are accurate to within $\pm 1\%$. (iv) (5%) The common-mode rejection ratio (CMRR), in dB.

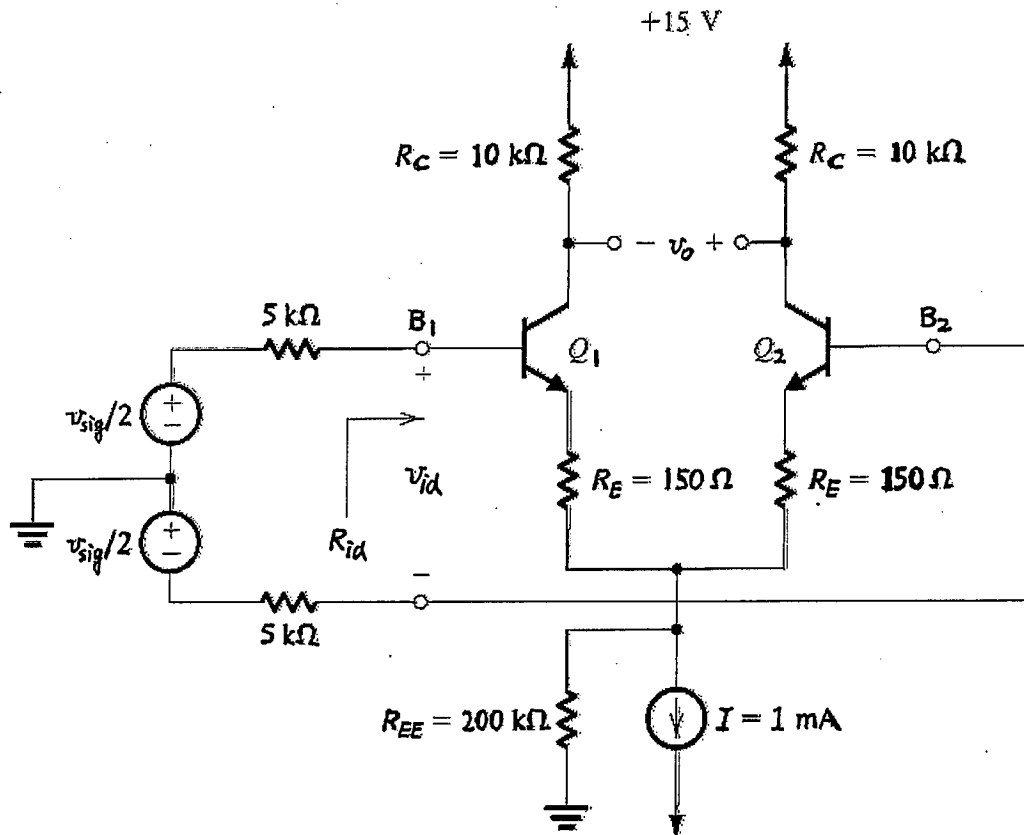

Figure 4

6. (15%) (i) (9%) Sketch a CMOS logic circuit that realize the function: $Y = \overline{A+B(C+D)}$
 (ii) (6%) Sketch a CMOS logic circuit that realize the function: $Y = ABC + \overline{A}\overline{B}\overline{C}$

國立中山大學99學年度碩士班招生考試試題

科目：工程數學甲【通訊聯招碩士班甲組、電機系碩士班甲組、丙組選考、丁組、戊組、庚組、通訊所碩士班乙組】

1. (10%) Find the solution to the following differential equation:

$$\dot{x}_1(t) = -2x_1(t) + x_2(t) \quad x_1(0) = 1$$

$$\dot{x}_2(t) = x_1(t) - 2x_2(t) \quad x_2(0) = -1$$

2. (15%) Consider a two-dimensional flow governed by the vector field $F(x,y) = (x^2 + y^2)\mathbf{i}$, and a domain D enclosed by curves C_1 and C_2 as illustrated in Figure 1. Define the flow into D as positive flow and out of D as negative flow. Calculate the net flow across the boundary of D .

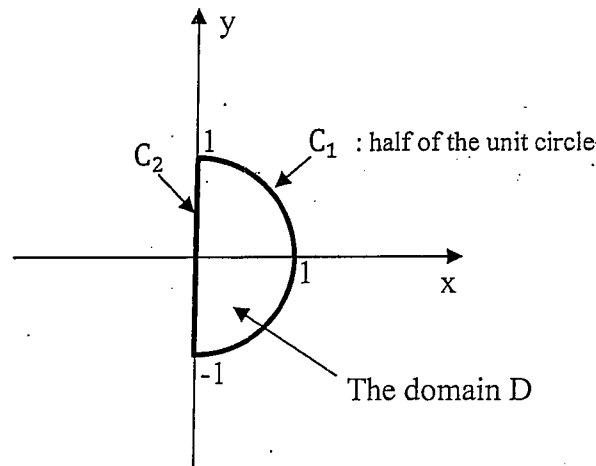

Figure 1: The domain D .

3. (a) (15%) Find the solution to the following wave equation:

$$\frac{\partial^2 w}{\partial t^2}(x,t) = \frac{\partial^2 w}{\partial x^2}(x,t) \quad \forall 0 < x < 1, t > 0$$

$$w(0,t) = w(1,t) = 0 \quad \forall t > 0$$

$$w(x,0) = 0 \quad \forall 0 < x < 1$$

$$\frac{\partial w}{\partial t}(x,0) = \sin 3\pi x + \sin 6\pi x \quad \forall 0 < x < 1$$

- (b) (5%) Besides the boundary points $x=0$ and $x=1$, what are the stationary points of the solution to the above wave equation; i.e., at what x 's $w(x,t)$ is equal to zero for all $t > 0$?

4. (15%) Let \mathbf{x} and \mathbf{y} be two vectors in the vector space V and let S be a set of vectors in V . Denote by $LC(\mathbf{x}, S)$ the set of all linear combinations of \mathbf{x} and any vector \mathbf{s} in S , i.e.,

$$LC(\mathbf{x}, S) := \{ \mathbf{v} = \alpha\mathbf{x} + \beta\mathbf{s} \mid \alpha, \beta \in \mathbb{R} \text{ and } \mathbf{s} \in S \}.$$

- (a) Show that if $LC(\mathbf{x}, S) \subset LC(\mathbf{y}, S)$, then $\mathbf{x} \in LC(\mathbf{y}, S)$. (5%)

- (b) Under what condition on set S will the implication " $\mathbf{x} \in LC(\mathbf{y}, S) \Rightarrow LC(\mathbf{x}, S) \subset LC(\mathbf{y}, S)$ " hold? Give the condition and show your answer. (10%)

5. (10%) Let M and N be two subspaces of \mathbb{R}^n such that $\mathbb{R}^n = M \oplus N$ and let P be the projection matrix that projects vectors of \mathbb{R}^n onto M along N .

- (a) Show that P is an idempotent matrix, i.e. $P^2 = P$. (5%)

- (b) Let λ be an eigenvalue of matrix P . Find all possible values of λ . (5%)

國立中山大學 99 學年度 碩士班 招生考試 試題

科目：工程數學甲【通訊聯招碩士班甲組、電機系碩士班甲組、丙組選考、丁組、戊組、庚組、通訊所碩士班乙組】

6. (15%) Evaluate the following integral

$$\oint_C z^{n-1} e^{1/z} dz$$

where z is a complex variable, and C is the circle $|z|=1$ in counterclockwise direction.

Hint: Find the Laurent series representation of $e^{1/z}$ first.

7. (15%) Let $F(\omega)$ and $G(\omega)$ be the Fourier transforms of two continuous signals $f(t)$ and $g(t)$ respectively. Prove that

$$\mathcal{F}(f(t)g(t)) = \frac{1}{2\pi} F(\omega) * G(\omega),$$

where \mathcal{F} stands for Fourier transform, and “*” is the convolution operator.

- 1 Consider a silicon PN junction diode. The avalanche breakdown happens when the maximum junction electric field equals to the critical field E_{crit} . Calculate the breakdown voltage for $N_D = N_A = 10^{16} \text{ cm}^{-3}$. (For silicon: $\epsilon_{Si} = 11.8 \epsilon_0$, $\epsilon_0 = 8.85 \times 10^{-14} \text{ F/cm}$, $E_{crit} = 3.5 \times 10^5 \text{ V/cm}$, also $q = 1.6 \times 10^{-19} \text{ C}$) (20%)
- 2 Consider a MOS capacitor with a p-type Si substrate doped to $N_a = 2 \times 10^{16} \text{ cm}^{-3}$. The SiO_2 thickness is 55 nm. Estimate the minimum capacitance C_{min} . (the dielectric constant for Si is $11.7\epsilon_0$, and $3.9\epsilon_0$ for SiO_2 , $\epsilon_0 = 8.85 \times 10^{-14} \text{ F/cm}$, the intrinsic carrier concentration for silicon: $n_i = 1.5 \times 10^{10} \text{ cm}^{-3}$) (20%)
- 3 Consider a MOSFET. (20%)
 - 3.1 Describe and explain the threshold voltage V_T variations with respect to the channel length L . (10%)
 - 3.2 Describe and explain the threshold voltage V_T variations with respect to the device width W . (10%)
- 4 Consider a Si NPN bipolar junction transistor. The parameters for base are : base width $W_b = 0.65 \mu\text{m}$, doping concentration $N_A = 2 \times 10^{16} \text{ cm}^{-3}$, electron diffusion coefficient $D_n = 25 \text{ cm}^2/\text{sec}$, and electron carrier life time $t_n = 6 \times 10^{-7} \text{ sec}$. The parameters for emitter are : doping concentration $N_D = 10^{18} \text{ cm}^{-3}$, hole diffusion coefficient $D_p = 12 \text{ cm}^2/\text{sec}$, and hole carrier life time $t_p = 10^{-7} \text{ sec}$. The emitter width is considered long enough to neglect its effect. Estimate the common base current gain β . (20%)
- 5 A Si solar cell with cross section area $3 \text{ cm} \times 3 \text{ cm}$ with $I_{th} = 30 \text{ nA}$ (reverse saturation current in the dark) has an optical generation rate of $10^{18} \text{ EHP/cm}^3\text{-s}$ within the electron/hole diffusion length $L_n = L_p = 1.5 \mu\text{m}$ and the depletion region. If the depletion width is $1 \mu\text{m}$, calculate the short circuit current and the open circuit voltage. (20%)

國立中山大學99學年度碩士班招生考試試題

科目：工程數學乙【電機系碩士班乙組】

1.(a) (5%) Consider the following function

$$u(t) = \begin{cases} 1 & \text{if } 1 \leq t \leq 2 \\ 0 & \text{otherwise} \end{cases}$$

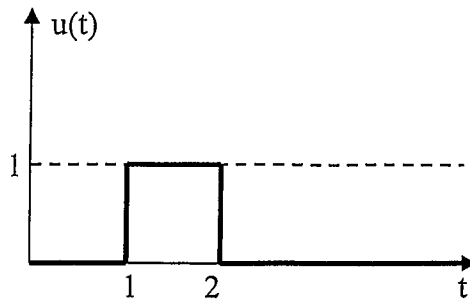
See Figure 1 for an illustration. Find the Laplace transform of $u(t)$.Figure 1: illustration of $u(t)$.

(b) (5%) Consider the following differential equation defined on the nonnegative real axis:

$$\dot{y}(t) + y(t) = u(t), \quad y(0) = 0, \quad (1)$$

where $u(t)$ is defined as in Problem 1 (a). Find $y(t)$ that satisfies equation (1).(c) (5%) Calculate the peak value and the steady state value of $y(t)$ that satisfies equation (1).

2.(a) (5%) Consider the following differential equation defined on the nonnegative real axis:

$$\ddot{y}(t) - 0.1\dot{y}(t) + y(t) = 0, \quad \dot{y}(0) = 0, y(0) = 1.$$

Does the solution of the above differential equation converge to zero as time t goes to infinity? You must justify your answer. No mark will be given if no justification is provided.

(b) (5%) Consider the following differential equation defined on the nonnegative real axis:

$$\ddot{y}(t) - 0.1\dot{y}(t) + 2y(t) = y(t-1), \quad \dot{y}(0) = 0, y(0) = 1.$$

Does the solution of the above differential equation converge to zero as time t goes to infinity? You must justify your answer. No mark will be given if no justification is provided.3. (20%) Let \mathbf{x} and \mathbf{y} be two vectors in the vector space V and let S be a set of vectors in V . Denote by $LC(\mathbf{x}, S)$ the set of all linear combinations of \mathbf{x} and any vector in S , i.e.,

$$LC(\mathbf{x}, S) := \{ \mathbf{v} = \alpha\mathbf{x} + \beta\mathbf{s} \mid \alpha, \beta \in \mathbb{R} \text{ and } \mathbf{s} \in S \}.$$

(a) Show that if $LC(\mathbf{x}, S) \subset LC(\mathbf{y}, S)$, then $\mathbf{x} \in LC(\mathbf{y}, S)$. (5%)(b) Show that if set S is a subspace and $\mathbf{x} \in LC(\mathbf{y}, S)$, then $LC(\mathbf{x}, S) \subset LC(\mathbf{y}, S)$. (8%)(c) Show that if, moreover, $\mathbf{x} \notin S$, then $LC(\mathbf{x}, S) = LC(\mathbf{y}, S)$. (7%)4. (25%) Let $L: V \rightarrow V$ be a one-to-one linear transformation on vector spaces V with $\dim(V) = n$ and let $\{\mathbf{v}_1, \dots, \mathbf{v}_n\}$ be a basis for V .

國立中山大學99學年度碩士班招生考試試題

科目：工程數學乙【電機系碩士班乙組】

- (a) Show that $L:V \rightarrow V$ is also an onto linear transformation. (10%)
 (Hint: You may need to show the linear independence of the set $\{L(\mathbf{v}_1), \dots, L(\mathbf{v}_n)\}$ first.)

Let M and N be two subspaces of \mathbb{R}^n such that $\mathbb{R}^n = M \oplus N$ and let P be the projection matrix that projects vectors of \mathbb{R}^n onto M along N .

- (b) Show that P is an idempotent matrix, i.e. $P^2 = P$. (4%)
 (c) Let λ be an eigenvalue of matrix P . Find all possible values of λ . (5%)
 (d) Let Q be another projection matrix that projects vectors of \mathbb{R}^n onto M along N . Find the *necessary* condition on the two products PQ and QP individually so that $(P+Q)$ is also a projection matrix that projects vectors of \mathbb{R}^n onto M along N . (6%)
 (Hint: You may need to find the values of $PQ+QP$ and $PQ-QP$, respectively, in solving the problem.)

5. (15%) Evaluate the following integral

$$\oint_C z^{n-1} e^{1/z} dz,$$

where z is a complex variable, and C is the circle $|z|=1$ in counterclockwise direction.

Hint: Find the Laurent series representation of $e^{1/z}$ first.

6. (15%) Let $F(\omega)$ and $G(\omega)$ be the Fourier transforms of two continuous signals $f(t)$ and $g(t)$ respectively. Prove that

$$\mathcal{F}(f(t)g(t)) = \frac{1}{2\pi} F(\omega) * G(\omega),$$

where \mathcal{F} stands for Fourier transform, and “*” is the convolution operator.

Problem 1 (25%) Consider the circuit in Fig. 1, where all the op-amps are ideal.

- (a) (10%) Let the input, the output, and the state be u , y , and $x = [x_1 \ x_2]^T$, respectively. The circuit is represented in the state space form:

$$\dot{x} = Ax + Bu, y = Cx$$

Find the matrix A and vector B .

- (b) (10%) Find the poles of the circuit.
 (c) (5%) Roughly draw the waveform of the circuit output in response to a unit step input under zero initial conditions.

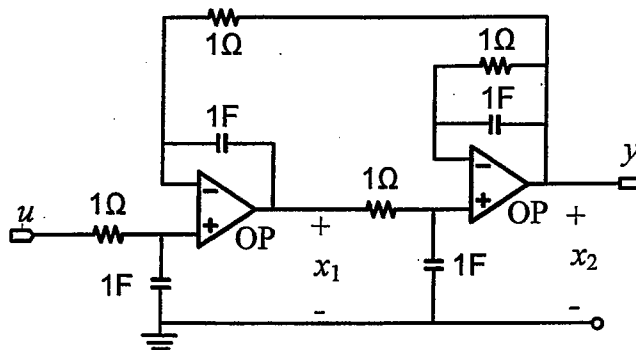

Fig. 1

Problem 2 (20%)

- (a) (5%) Please state the definition of internal stability of a feedback system.
 (b) (15%) Given the plant $P(s)$ with an unstable pole at $s=1$ and an unstable zero at $s=2$ in Fig. 2. What are the conditions on the sensitivity function $S(s)$ for internal stability of this feedback system? (Hint: Should $S(s)$ be stable or not? Should $S(s)$ satisfy some interpolation conditions?)

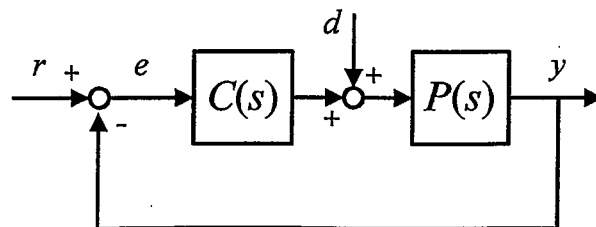

Fig. 2.

Problem 3 (30%) Suppose we want to regulate the velocity y of a mass m that is supported by a damper with damping coefficient b , as shown in Fig. 3. The control strategy is to attach a movable plate through a spring of spring constant k to the mass, and control the mass velocity y by moving the plate with the desired velocity r . Assume the damper and the spring are ideal and linear.

- (a) (15%) The entire control system can be drawn as a block diagram in Fig. 2. Find $C(s)$, $P(s)$, and disturbance d .
- (b) (5%) Given a constant r , would the mass velocity y eventually follow the desired velocity r with no error using this control strategy? Justify your answer.
- (c) (10%) Given $m=b=1$, choose the spring constant k such that the feedback system is critically damped.

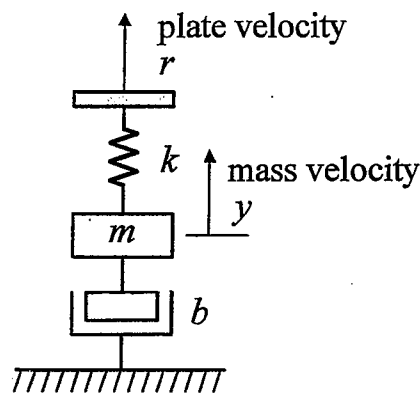

Fig. 3

Problem 4 (25%) Consider the control system displayed in Fig. 2 with

$$C(s)=1 \text{ and } P(s) = 2e^{-0.1s} / (s+1)^2.$$

- (a) (5%) Is the plant minimum phase or not?
- (b) (10%) Roughly sketch the Nyquist locus of the control system. Is it stable?
- (c) (10%) Estimate its phase margin.

Note: All answers above need justifications or no scores will be given.

國立中山大學99學年度碩士班招生考試試題

科目：離散數學【電機系碩士班丙組選考】

1. Use Euclidean Algorithm to find the great common divisor of $7n+3$ and $5n+2$ ($n \in \mathbb{N}$). [10%]
2. Prove that if we select 101 integers from the set $S = \{1, 2, 3, \dots, 200\}$, there exist two integers m, n in the selection where $\gcd(m, n) = 1$. [10%]
3. With $A = \{x, y, z\}$, let $f, g: A \rightarrow A$ be given by $f = \{(x, y), (y, z), (z, x)\}$, $g = \{(x, y), (y, x), (z, z)\}$. Determine each of the following: $f \circ g$, g^{-1} , $(g \circ f)^{-1}$, $f^{-1} \circ g^{-1}$, and $g^{-1} \circ f^{-1}$. [10%]
4. For the finite state machine given in the following table, determine a minimal machine that is equivalent to it. [20%]

	v		w	
	0	1	0	1
s_1	s_7	s_6	1	0
s_2	s_7	s_7	0	0
s_3	s_7	s_2	0	0
s_4	s_2	s_3	1	0
s_5	s_3	s_7	0	0
s_6	s_4	s_1	0	0
s_7	s_3	s_5	0	0
s_8	s_7	s_3	0	0

5. Let the input alphabet I and output alphabet O be both $\{0, 1\}$. Construct a state diagram for a finite state machine that reverses (from 0 to 1 or from 1 to 0) the symbols appearing in the 4th, in the 8th, in the 12th, ..., position of an input string $x \in I^+$. For example, if s_0 is the starting state, then $\omega(s_0, 0000) = 0001$, $\omega(s_0, 000111) = 000011$, and $\omega(s_0, 000000111) = 000100101$. (Here ω is the output function.) [10%]
6. Let A be a set with $|A| = n$ and \mathcal{R} be a relation on A that is antisymmetric. How many \mathcal{R} can be defined? [10%]
7. How many ways can we select seven nonconsecutive integers from $\{1, 2, 3, 4, \dots, 50\}$? [10%]
8. Find the chromatic polynomials of the following graph. [20%]

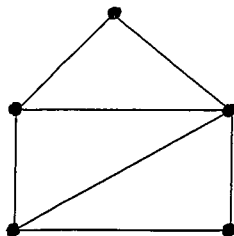

1. [10] We define a traversal of a binary tree, with a `treePointer` pointing to its root, as follows:

```
Algorithm tree-traversal(treePointer ptr)
```

```
  If(ptr)
```

```
    {Call tree-traversal(ptr → rightChild);
```

```
    Call tree-traversal(ptr → leftChild);
```

```
    Print out the content stored in the node pointed to by ptr;}
EndAlgorithm
```

Please traverse the binary tree shown in Figure 1 using this algorithm. Note that each node in this figure stores one integer shown in the node.

2. [10] Let $f(n)$ and $g(n)$ be functions mapping nonnegative integers to real numbers. We say that $f(n)$ is order $g(n)$ if there is a real constant c greater than zero and an integer constant n_0 greater than or equal to one, such that $f(n)$ is less than or equal to $cg(n)$ for every integer n greater than or equal to n_0 . Using this definition, please show that $40n^3 + 10n \log n + 6$ is order $n^4 + 8n$.
3. [10] Assume we want to use a circular, doubly linked list to store characters. Assume that the first character 'n' is stored at address 2500, the second character 's' is stored at address 1500, the third character 'y' is stored at address 2000, the fourth character 's' is stored at address 1100, and the fifth character 'u' is stored at address 5000. Let the address of the first character is stored in the variable named *head*. Please show the contents of *head* and all the nodes of the list. Note that you have to show the contents of the pointers explicitly, not just using arrows. No credits will be given for an answer with arrows only.
4. [10] Consider the graph of Figure 2. Please traverse the graph, starting with node 1, using
- [5] breadth-first search,
 - [5] depth-first search.

Assume that nodes with smaller numbers are selected earlier than the ones with larger numbers during the search.

5. [5] The array shown below is a max heap with 13 integers. Insert 95 into the array and make it into a max heap again. Show the resulting array.

	120	105	85	75	80	70	50	40	45	30	60	32	67		
0	1	2	3	4	5	6	7	8	9	10	11	12	13	14	15

6. [5] The array shown below is a max heap with 14 integers. Remove 85 from the array and make it into a max heap again. Show the resulting array.

	85	60	55	45	50	40	25	10	15	2	35	5	27	19	
0	1	2	3	4	5	6	7	8	9	10	11	12	13	14	15

7. [10] One way to implement a binary tree T is to use a linked structure. In this approach, we represent each node v of T by an object which stores the associated element and pointers to the nodes for the children and parents of v . In the object of node v , the element field keeps the content to be stored in node v , the parent field stores the pointer to the parent of node v , the left-child field stores the pointer to the left-child of node v , and the right-child field stores the pointer to the right-child of node v . If v is the root of T , then the pointer to the parent node is $NULL$, and if v doesn't have a certain child, then the pointer to the child is $NULL$. Please construct the linked structure for the binary tree shown in Figure 3 and draw it out graphically, with arrows indicating pointers. Note that each node in this figure stores one character shown in the node.
8. [10] Let $d(n)$, $e(n)$, $f(n)$, and $g(n)$ be functions mapping nonnegative integers to nonnegative reals. Suppose we have the following rules:
- R1: If $d(n)$ is $K(f(n))$, then $ad(n)$ is $K(f(n))$, for any constant a greater than zero.
 R2: If $d(n)$ is $K(f(n))$ and $e(n)$ is $K(g(n))$, then $d(n) + e(n)$ is $K(f(n) + g(n))$.
 R3: If $d(n)$ is $K(f(n))$ and $e(n)$ is $K(g(n))$, then $d(n)e(n)$ is $K(f(n)g(n))$.
 R4: If $d(n)$ is $K(f(n))$ and $f(n)$ is $K(g(n))$, then $d(n)$ is $K(g(n))$.
 R5: n^x is $K(a^n)$ for any fixed constants x greater than zero and a greater than one.
 R6: $\log n^x$ is $K(\log n)$ for any fixed constant x greater than zero.
 R7: $\log^x n$ is $K(n^y)$ for any fixed constants x greater than zero and y greater than zero.
- Using these rules, prove that $30n^3 + 7n^2 \log^3 n$ is $K(n^3)$. Please indicate the rules used.
9. [5] Consider the B-tree of order 3 shown in Figure 4. Please insert 90 into it and draw the resulting B-tree.
10. [5] Consider the B-tree of order 3 shown in Figure 4. Assume that a node to be deleted is replaced by the largest integer of its left subtree. Please delete 50 from it and draw the resulting B-tree.
11. [10] Consider the following algorithm:
- ```

Input: An integer array A and integers i and n
Output: Array A
Algorithm process(A, i, n)
 If $n > 1$ then
 {Swap $A[i]$ and $A[i + n - 1]$;
 Call process($A, i+1, n-2$);}
 Return A ;
EndAlgorithm

```

Suppose  $A$  is a 16-element array containing, starting with index 0, 16 integers: 2,

4, 6, 8, 10, 12, 14, 16, 18, 20, 22, 24, 26, 28, 30, 32. What will A contain after calling process(A, 2, 12)?

12. [10] Consider the algorithm given in Problem 11. For an array A containing  $n$  elements, what is the running time, in big-O, of process(A, 0, n)? Please justify your answer.

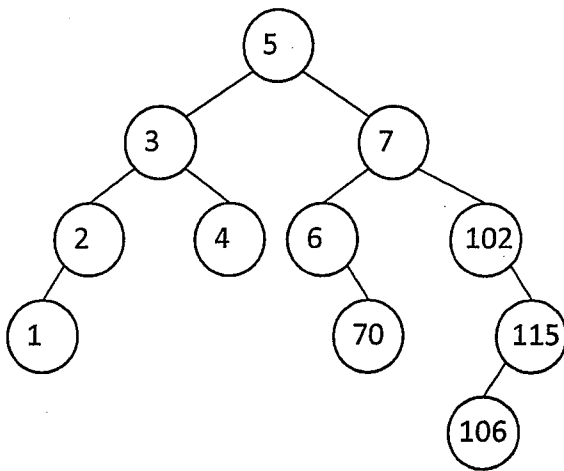

Figure 1

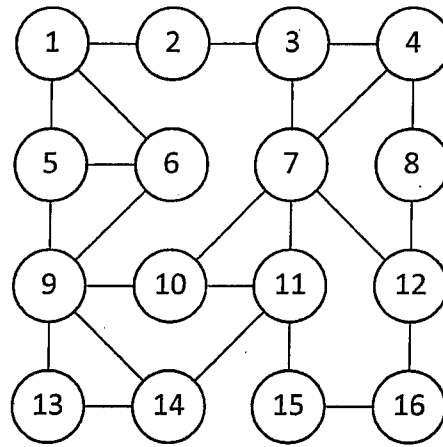

Figure 2

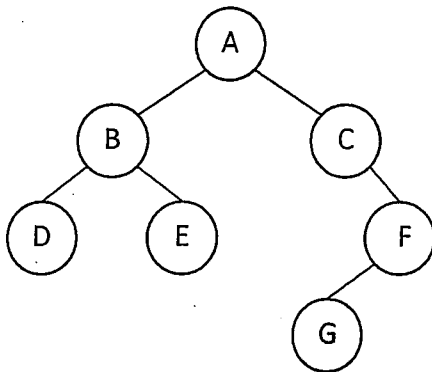

Figure 3

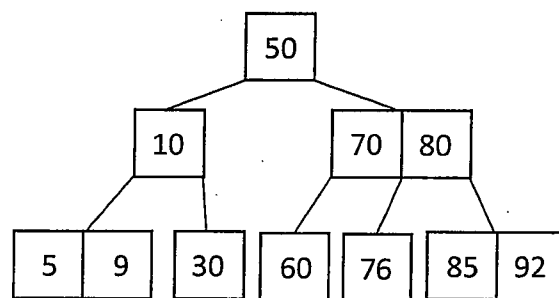

Figure 4

**Thank You for Your Attention, and Good Luck!**

## 國立中山大學99學年度碩士班招生考試試題

科目：數位電路【電機系碩士班丙組選考、庚組】

[Problem 1] By Boolean algebra to determine and prove whether or not the following expressions are valid, i.e. whether the left- and right-hand sides represent same function. (10%)

a.  $x_1 \cdot x_2 + x_2 \cdot x_3 + x_1 \cdot x_3 = x_3 \cdot (\overline{x_1} \cdot x_2 + x_1 \cdot \overline{x_2}) + x_1 \cdot x_2$

b.  $x_1 \cdot \overline{x_3} + \overline{x_2} \cdot \overline{x_3} + x_1 \cdot x_3 + \overline{x_2} \cdot x_3 = \overline{x_1} \cdot \overline{x_2} + x_1 \cdot x_2 + x_1 \cdot \overline{x_2}$

[Problem 2] Consider the function  $f = \overline{x_1} + \overline{x_2} \cdot \overline{x_3}$ , and implement it as a MOS gate. (10%)

[Problem 3] Design a 2-to-4 binary decoder named dec24, and design a 3-to-8 binary decoder with dec24 modules. (10%)

[Problem 4] Design a four-bit carry-lookahead adder using the basic gates such as NOT, AND, OR, NAND, NOR and XOR. (10%) By the four-bit carry-lookahead adder module (named CLA4), design a 32-bit adder. Let the basic gates take the same delay time as 1d. The delay time of the critical path of the 32-bit adder must be limited under 16d. (10%)

[Problem 5] Given the positive-edge-triggered D flip-flop (named Dff), any kind of multiplexers and the basic gates such as NOT, AND, OR, NAND, and NOR, design a four-bit modulo-12 Up/Down counter. (20%)

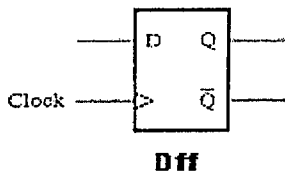

[Problem 6] In VHDL or Verilog HDL, write a frequency divider with the 50% duty cycles, which has two inputs  $f_{in}$  and 16-bit divisor N and has one output  $f_{out}$ . (10%)

$$f_{out} = f_{in} / N$$

[Problem 7]

(a) Write the code for a negative-edge-triggered D flip-flop with synchronous reset in VHDL or Verilog HDL. (5%)

(b) In VHDL or Verilog HDL, write the code for the traffic light controller, whose lighting sequences are as Figure 1. After the red lamp lights 3 cycles, the green lamp lights 3 cycles. After the green lamp lights, the yellow lamp lights 1 cycle. (15%)

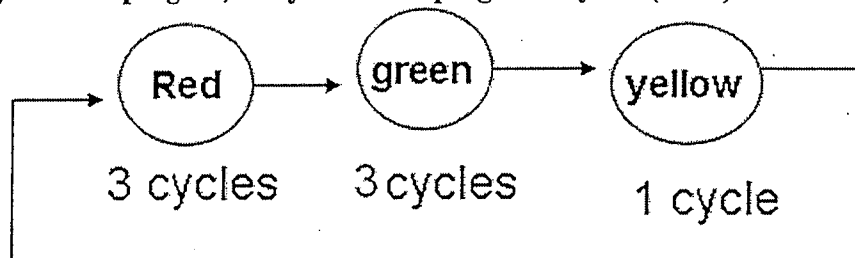

Figure 1. The sequences of the traffic light

## 國立中山大學99學年度碩士班招生考試試題

## 科目：計算機結構【電機系碩士班丙組、庚組】

- I. (20%) A 2.0 GHz processor executes programs with 1000 instructions per program on average. An instruction cycle of the processor consists of four stages: fetching, decoding, executing, and storing. It requires 1 cycle for decoding and 1 cycle for executing one instruction, 2 cycles for fetching the op code or operands from memory, and 2 cycles for storing the results back to memory. Assume (i) 20% of the instructions are immediate addressing, (ii) 30% are direct addressing, (iii) 50% are indirect addressing, and (iv) no instruction pipelining.
- (1) (10%) Calculate the MIPS of the processor.
  - (2) (10%) Calculate the average CPU throughput (programs/sec).
- II. (20%) Design a memory of total capacity 8192 bits using SRAM chips of size 32x1 bit.
- (1) (10%) Draw the array configuration of the 256 chips on the memory board with 16 rows and 16 columns by showing the decoder, all required input (16-bit address) and output signals (16-bit data), if the design only allows for 16-bit word accesses.
  - (2) (10%) Redraw the array configuration, if the design should allow for both 8-bit and 16-bit word accesses.
- III. (20%) Floating-Point representations and Computer Arithmetic
- (1) (5%) Using IBM's 32-bit floating-point format (7-bit exponent, exponent bias = 64, and base = 16) to represent -240 (Assume no normalization is used).
  - (2) (5%) Using IEEE 32-bit floating point format to represent  $-1/32$  (8-bit exponent, exponent bias = 127, and base = 2).
  - (3) (10%) Using the **Booth's algorithm** to perform the following *signed-integer multiplication*.  

$$(-7) \times (-6) = (+42)$$
- IV. (20%) A synchronous-mode pipeline consists of latches for lock-step synchronization and stages for data processing. The optimal choice of the number of the pipeline stages should be able to maximize a performance cost ratio (PCR). Given the following six parameters for a pipeline,
- (i) F = clock frequency, (ii) K = number of pipeline stages, (iii) C = total cost of all logical gates of stages, (iv) H = the cost of each latch, (v) T = total time required for a non-pipeline sequential program, and (vi) D = delay in a latch.
  - (1) (10%) Derive an equation for PCR using the above-mentioned parameters.
  - (2) (10%) Calculate the optimal number of pipeline stages that can maximize the PCR.
- V. (20%) Given the following assembly language codes (S1 to S7). Perform flow analysis and draw the dependency graph (flow, output, and anti) among all the statements.
- |     |          |            |                          |
|-----|----------|------------|--------------------------|
| S1: | Add      | R7, R1, R2 | /* (R7) ← (R1) + (R2) */ |
| S2: | Subtract | R1, R1, R2 |                          |
| S3: | Multiply | R7, R7, R1 |                          |
| S4: | Add      | R8, R3, R4 |                          |
| S5: | Subtract | R9, R3, R4 |                          |
| S6: | Divide   | R8, R8, R9 |                          |
| S7: | Add      | R9, R7, R8 |                          |

Note: In drawing your graph, you may use ----> to represent flow dependency,  
 --o--> to represent output dependency,  
 --|-> to represent anti-dependency.

1.(20%) Find power consumption for all components in Fig. 1.

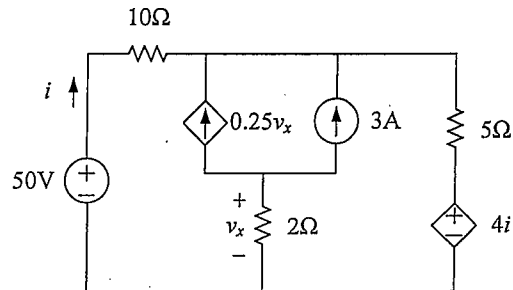

Fig. 1

2.(10%) In Fig. 2, assume the inductor current  $i(t)$  is 0 for  $t < 0$ . If ideal switches  $S_1$  and  $S_2$  are closed at  $t=0$ s and  $t=2$ s, respectively, find  $i(t)$  for  $t > 0$ .

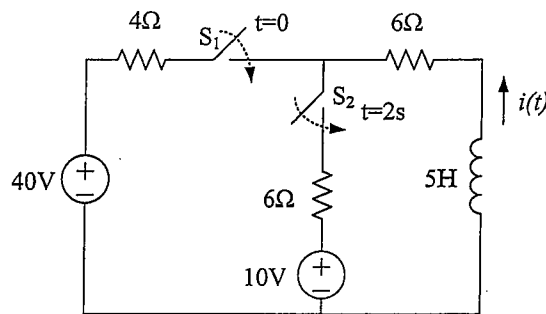

Fig. 2

3.(20%) Find  $i(t)$ ,  $v_o(t)$ , average power on resistor, reactive power on capacitor, and reactive power on inductor in Fig. 3.

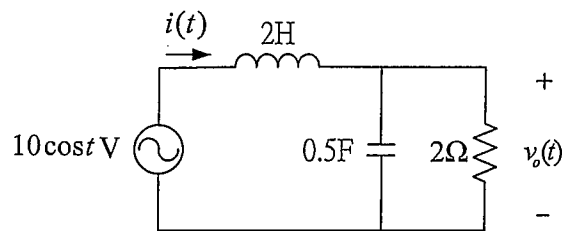

Fig. 3

4.(10%) Find phasor current  $I$  and phasor voltage  $V_o$  in Fig. 4.

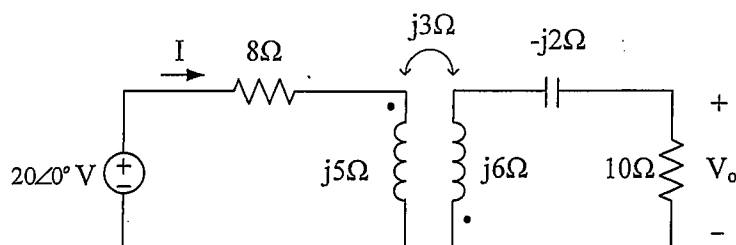

Fig. 4



5.(10%) For the s-domain circuit in Fig. 5, find

(A) (5%) Transfer function  $V_o/V_i$ .

(B) (5%) The response when  $v_i(t)=\cos 2t$ .

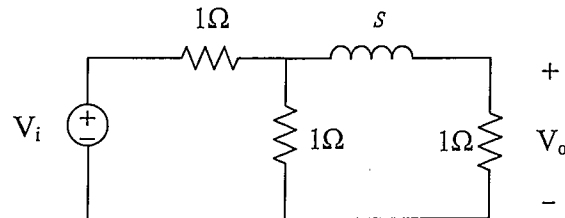

Fig. 5

6.(10%) Find  $v_o$  in Fig. 6.

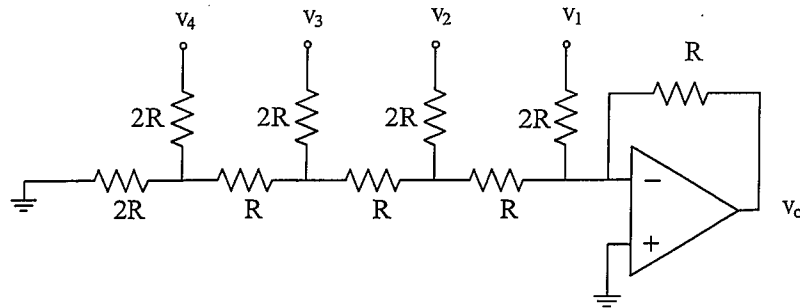

Fig. 6

7.(10%) Give the reasons why the capacitor looks like an open circuit, but the inductor becomes a short circuit under the dc condition. Also, explain why both the current flowing through the inductor and the voltage across on the capacitor have to be continuous waves?

8.(10%) Nowadays, photovoltaic (PV) or solar power is one of popular renewable energy sources. Power converting equipment is normally required between PV panel and the utility for proper power delivery. Please describe functionality and necessity of the so-called power converting equipment in this application.

國立中山大學99學年度碩士班招生考試試題

科目：電力工程【電機系碩士班丁組】

- Determine the operational information ( $V_2$  at Bus 2, line currents  $i_{12}$ , line losses between busses 1 and 2, and complex power supplied by the generator) of the following simple 2-bus power system by using the Newton-Raphson's method for one iteration (initial values of  $|V_2|=1.0$  p.u.,  $\delta_2=0^\circ$ ) (25%).

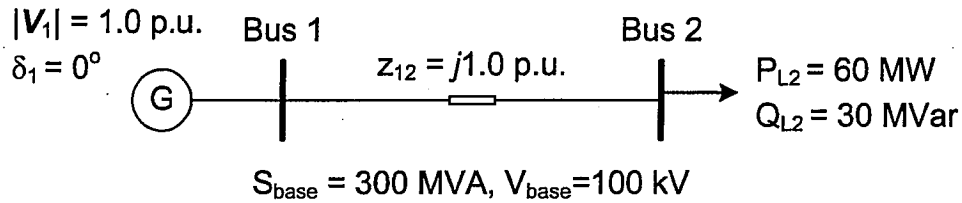

- When a 3-phase line to ground fault is occurred at Bus 2, find the corresponding 3-phase currents and voltages at this bus (all the per-unit values are based on the individual item's own ratings) (25%).

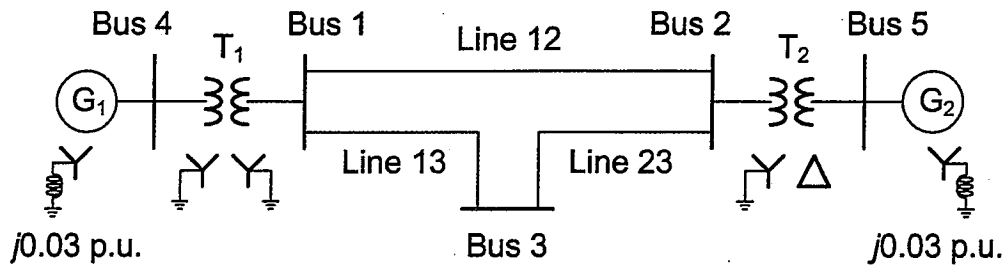

| Item           | MVA rating | Voltage rating (kV) | $x_1$ (p.u.) | $x_2$ (p.u.) | $x_0$ (p.u.) |
|----------------|------------|---------------------|--------------|--------------|--------------|
| G <sub>1</sub> | 100        | 25                  | 0.20         | 0.20         | 0.05         |
| G <sub>2</sub> | 100        | 13.8                | 0.20         | 0.20         | 0.05         |
| T <sub>1</sub> | 100        | 25/230              | 0.05         | 0.05         | 0.05         |
| T <sub>2</sub> | 100        | 230/13.8            | 0.05         | 0.05         | 0.05         |
| Line 12        | 100        | 230                 | 0.1          | 0.1          | 0.3          |
| Line 13        | 100        | 230                 | 0.1          | 0.1          | 0.3          |
| Line 23        | 100        | 230                 | 0.1          | 0.1          | 0.3          |

- If a DC shunt generator is rated at 2 kW, 100 V, 1800 rpm, with an armature resistance of  $0.1 \Omega$ , and the total resistance of the shunt field winding is  $200 \Omega$ . Calculate the internal armature generated voltage  $E_a$  at rated electric power output condition. If the machine magnetization can be assumed linear and the generator output power is increased to 2.2 kW while it is still providing the rated voltage output, what will be the machine speed (in rpm) and operational efficiency now (assume no mechanical losses) (25%)?
- A 60 Hz, 381 V induction motor is operated at certain condition such that it will receive a total 3-phase power of 15 kVA at a power factor of 0.85 lagging. To improve the overall power factor from the supply to unity, a 3-phase, 6-pole synchronous motor at 12 kVA is connected directly in parallel with the induction motor. If the stator winding resistance of this synchronous motor can be neglected and its friction and rotational losses can be accounted by 150 W, what is the output torque of this synchronous motor (25%)?

國立中山大學99學年度碩士班招生考試試題

科目：電磁學【通訊聯招碩士班甲組、電機系碩士班戊組、通訊所碩士班乙組】

- A spherical conducting shell of radius  $a$ , centered at the origin, is maintained at a potential  $V_0$  (zero potential at infinity) in air. Denote  $r = \sqrt{x^2 + y^2 + z^2}$

  - Determine potential function  $V(r)$  for  $r < a$  and  $r > a$ . (10%)
  - Determine the electric field intensity  $\mathbf{E}$  for  $r < a$  and  $r > a$ . (10%)
  - Find the energy stored in the electric field. (5%)
- A very long, straight wire is along the  $z$ -axis. The tips of a triangular loop are located at  $(d, 0, 0)$ ,  $(d+b, 0, 0)$ , and  $(d, 0, d+b)$ . Find the mutual inductance between the straight wire and the loop. (15%)
- The three regions shown in Fig.P3 contain perfect dielectrics. For a wave in medium 1 incident normally upon the boundary at  $z = -d$ , what combination of  $\epsilon_{r2}$  and  $d$  produces no reflection? Express the answer in terms of  $\epsilon_{r1}$ ,  $\epsilon_{r3}$  and  $f$  of the wave. (20%)

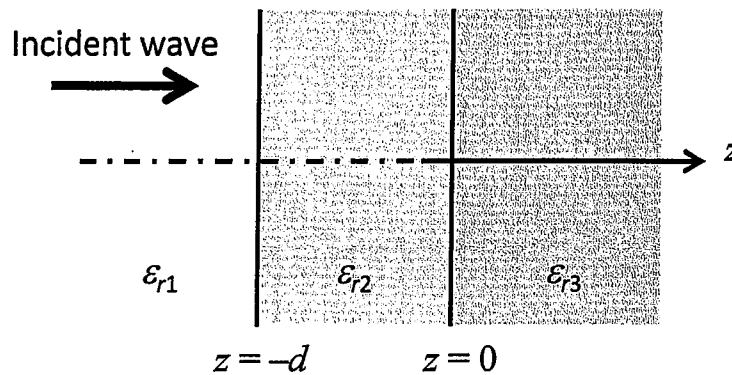

Fig.P3

- Fig.P4 shows an open-circuited transmission line connected to a source with internal resistance of  $50\Omega$  and source voltage

$$V_g(t) = V_0 \cos(3f_0t) \cos(f_0t)$$

with  $\ell = \lambda/4$  at  $f = f_0$ . Find the root-mean-square (rms) values of the line voltage and current at  $z = 0$ ,  $z = -\ell/2$  and  $z = \ell$ . (20%)

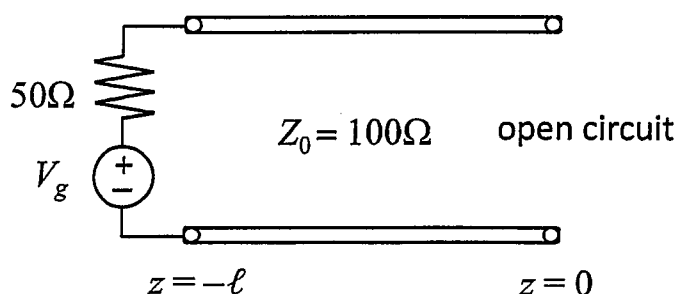

Fig.P4

## 國立中山大學99學年度碩士班招生考試試題

科目：電磁學【通訊聯招碩士班甲組、電機系碩士班戊組、通訊所碩士班乙組】

5. A rectangular air-filled waveguide has a cross-section of  $45 \times 90$  mm. Find
- cutoff wavelength  $\lambda_c$  for the dominant mode,
  - relative phase velocity  $u_p/c$  in the guide at a frequency of  $1.6 f_c$ ,
  - cutoff wavelength if the guide is filled with a dielectric of  $\epsilon_r = 1.7$ , and
  - relative phase velocity  $u_p/c$  with the dielectric at  $1.6 f_c$ .

(20%)

單選題 (4x5%=20%):

1. Let

$$A = \begin{bmatrix} 3 & 1-i \\ 1+i & 4 \end{bmatrix}$$

which is not true in the following:

- A is an Hermitian matrix
  - A is positive definite
  - Determinant of A is 10
  - Eigenvalues of A are -2 and 5
  - Trace of A is 7
2. Given singular value decomposition of a matrix  $H \in \mathbb{C}^{m \times n}$  as  $H = U\Sigma V^H$ , where  $\Sigma = \text{diag}(\sigma_1, \dots, \sigma_r, 0, 0, \dots)$ , and  $r = \text{rank}(H)$ . In the following, which is false:
- The non-zero eigen-values of  $HH^H$  are identical to that of  $H^H H$
  - The non-zero eigen-values of  $HH^H$  are  $\sigma_1^2, \dots, \sigma_r^2$ .
  - The eigen-vectors of  $HH^H$  equals to the columns of V
  - The singular values  $\sigma_1, \dots, \sigma_r$  are all positive
  - $\sum_{i=1}^r \sigma_i^2 = \sum_{i=1}^M \sum_{j=1}^M |h_{i,j}|^2$
3. Let  $A = \sum_{i=1}^Q p_i p_i^H$ , where  $\{p_i \in \mathbb{C}^{Q \times 1}\}$  is a set of orthonormal vectors. In the following, which is false:
- A is unitary
  - A is symmetric
  - $p_i$  is an eigen-vector of A
  - All eigen-values of A equal to 1
  - Given  $\{\alpha_i \neq 0\}$ ,  $\alpha_1 p_1 + \alpha_2 p_2 + \dots + \alpha_Q p_Q$  is an eigenvector of A
4. Given  $m \times m$  matrices A and B, which statement is not always true in the following.
- $\text{Trace}(AB) = \text{Trace}(BA)$
  - For any  $n \times 1$  vectors x and y,  $x^H A y = x^H B y \Leftrightarrow A = B$
  - If A is skew-symmetric, then, for any  $n \times 1$  vectors x,  $x^T A x = 0$
  - If B is positive definite and  $x^H B x = 0$ , x must be zero.
  - If A is unitary,  $|\det(A)| = 1$

## 計算證明題

1. Consider the following matrix

$$A = \begin{bmatrix} 0 & 0 & 0 & 1 \\ 0 & 0 & 1 & 0 \\ 0 & 1 & 0 & 0 \\ 1 & 0 & 0 & 0 \end{bmatrix}$$

- (a) Please explain Cayley-Hamilton theorem and give an example to demonstrate it. (10%)
- (b)  $A^{99} = ?$  (5%)

2. Consider the following matrix

$$A = \begin{bmatrix} -1 & 0 \\ 1 & -1 \\ 1 & 1 \end{bmatrix}$$

- (a) Please find the eigenvalues and eigenvectors of the matrix  $AA^T$ , where  $A^T$  is the transport of  $A$ . (5%)
- (b) Please calculate the singular value decomposition (SVD) of  $A$ . (5%)

3. Please use LU decomposition to solve the following system of linear equation (10%)

$$\begin{aligned} x_1 - 2x_2 + x_3 - 3x_4 &= 20 \\ -x_1 + x_2 + x_3 + 2x_4 &= -8 \\ -2x_1 + 3x_2 + x_3 + 4x_4 &= -21 \\ 3x_1 - 4x_2 - x_3 - 8x_4 &= 40 \end{aligned}$$

4. Let  $A$  be an  $m \times m$  matrix, please derive the necessary and sufficient condition of  $A$  being diagonalizable. (15%)
5. Let  $U$  and  $V$  be two  $m \times m$  positive definite matrices.
- (a) Find a  $m \times 1$  complex vector  $\mathbf{b}$ , such that

$$Q = \frac{\mathbf{b}U\mathbf{b}^H}{\mathbf{b}V\mathbf{b}^H}$$

is maximized (5%)

- (b) What is the maximum value of  $Q$  in (a)? (5%)

6. Given the following linear equations:

$$x + 2y = 2$$

$$3x - y = 1$$

$$x - y = -3$$

$$x + 2y = 10$$

(a) Show that the system described above has no solution. (5%)

(b) Find the least-square approximate solution of above system. (5%)

7. (a) Apply the Gram-Schmidt process to the following vectors to form a set of orthonormal bases. (5%)

$$\mathbf{u}_1 = \begin{bmatrix} 1 \\ 0 \\ 1 \\ 0 \end{bmatrix}, \quad \mathbf{u}_2 = \begin{bmatrix} 0 \\ 0 \\ 1 \\ 1 \end{bmatrix}, \quad \mathbf{u}_3 = \begin{bmatrix} 0 \\ 1 \\ 1 \\ 1 \end{bmatrix}$$

(b) Find the QR decomposition of (5%)

$$\mathbf{A} = \begin{bmatrix} 1 & 0 & 0 \\ 0 & 0 & 1 \\ 1 & 1 & 1 \\ 0 & 1 & 1 \end{bmatrix}$$

## 國立中山大學99學年度碩士班招生考試試題

科目：機率【通訊聯招碩士班乙組、電機系碩士班己組、通訊所碩士班甲組】

1. (Totally, 20 pts) Let  $X$  be a Normal random variable with mean 2 and variance 5.
- (a) (10 pts) Derive and find the mean and variance of the random variable  $Y = 6X + 8$ .
- (b) (10 pts) Derive and find the mean and variance of the random variable  $Y = 6X^2$ .
2. (Totally, 15 pts) Box 1 contains 2000 components of which 10 percent are defective. Box 2 contains 500 components of which 20 percent are defective. Boxes 3 and 4 contain 1000 each with 10 percent defective. We select at random one of the boxes and we remove at random a single component.
- (a) (8 pts) What is the probability that the selected component is defective?
- (b) (7 pts) What is the probability that this defective component came from Box 2?
3. (Totally, 15 pts) Show that for a random variable  $X$  with mean  $\eta$  and variance  $\sigma^2$ , the following inequality holds for any positive number  $\varepsilon$ :

$$P\{|X - \eta| \geq \varepsilon\} \leq \frac{\sigma^2}{\varepsilon^2}$$

4. (Totally, 15 pts) A firehouse is to be built at some point along a road of length  $L$ . A fire is uniformly likely to occur at any point along the road.
- (a) (8 pts) If we build the firehouse at a point at distance  $a$  from the left endpoint of the road, what is the expected distance the fire truck will have to travel to the fire?
- (b) (7 pts) Where should the firehouse be located to minimize the expected travel distance to a fire?
5. (Totally, 15 pts) Let  $p_X$  be a probability function for a discrete probability distribution. Let

$x_1 < x_2 < x_3 < \dots$  be all the values for which  $p_X(x_i) > 0$ . Let  $U_1 \sim \text{Uniform}[0,1]$ . Define  $Y$  by

$$Y = \min \left\{ x_j : \sum_{k=1}^j p_X(x_k) \geq U_1 \right\}.$$

Please find the probability function of  $Y$ .

6. (Totally, 20 pts) For a Poisson random variable  $X$  with parameter  $\lambda$ , show that
- (a) (10 pts)

$$P(0 < X < 2\lambda) > \frac{\lambda - 1}{\lambda};$$

- (b) (10 pts)

$$E[X(X-1)] = \lambda^2, \text{ and } E[X(X-1)(X-2)] = \lambda^3.$$



## 通訊理論 (Communications Theory)

1. (10 points) Based on the frequency bands, arrange and write the following communication systems in order (from low to high frequencies).  
 (A) Point-to-point microwave (B) Standard AM broadcast (C) Cellular Mobile Radio  
 (D) Worldwide Submarine Communication (E) FM broadcast
2. (10 points) Compare full AM with PAM, emphasizing the similarities and differences, particularly on  
 (a) the envelope of the modulated signal  
 (b) carrier  
 (c) spectrum
3. (15 points) The power spectral density of a random process  $X(t)$  is shown below. It consists of a delta function at  $f = 0$  and a rectangular component.

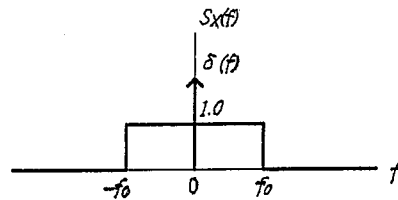

- (a) (6 points) Determine and sketch the autocorrelation function  $R_X(\tau)$  of  $X(t)$ .  
 (b) (3 points) What is the DC power contained in the  $X(t)$ ?  
 (c) (3 points) What is the AC power contained in the  $X(t)$ ?  
 (d) (3 points) If  $X(t)$  is sampled, determine the lower bound of sampling frequency so that  $X(t)$  is uniquely determined by its samples.
4. (15 points) Let a message signal  $m(t)$  be transmitted using single-sideband modulation. The power spectral density of  $m(t)$  is
- $$S_M(f) = \begin{cases} 2 \frac{|f|}{W}, & |f| \leq W \\ 0, & \text{otherwise} \end{cases}$$
- where  $W$  is a constant. White Gaussian noise of zero mean and power spectral density  $N_0/2$  is added to the SSB modulated wave at the receiver input.
- (a) (6 points) Determine the average signal power.  
 (b) (9 points) Assume that a modulated wave is expressed as  $s(t) = \frac{1}{2} A_c \cos(2\pi f_c t) m(t) + \frac{1}{2} A_c \sin(2\pi f_c t) \hat{m}(t)$ , where  $\hat{m}(t)$  is the Hilbert transform of the message signal  $m(t)$ . Find the output signal-to-noise ratio of the SSB receiver.

5. (15 points) Nyquist pulse-shaping criterion (Nyquist condition for zero ISI)

- (a) (10 points) Show that the necessary and sufficient condition for  $x(t)$  to satisfy  $x(nT) = \begin{cases} 1 & (n=0) \\ 0 & (n \neq 0) \end{cases}$  is that its Fourier transform  $X(f)$  satisfy  $\sum_{m=-\infty}^{\infty} X(f + m/T) = T$ .
- (b) (5 points) Suppose that the signal has a bandwidth of  $W$ . Determine  $X(f)$  for the case of  $T=1/2W$ .

## 國立中山大學99學年度碩士班招生考試試題

科目：通訊理論【通訊聯招碩士班乙組、電機系碩士班己組、通訊所碩士班甲組】

6. (10 points) Consider the two 8-point QAM signal constellations shown in the following figure. The minimum distance between adjacent points is  $2A$ .

(a) (5 points) Determine the average transmitted power for each constellation, assuming that the signal points are equally probable.

(b) (5 points) Which constellation is more power-efficient?

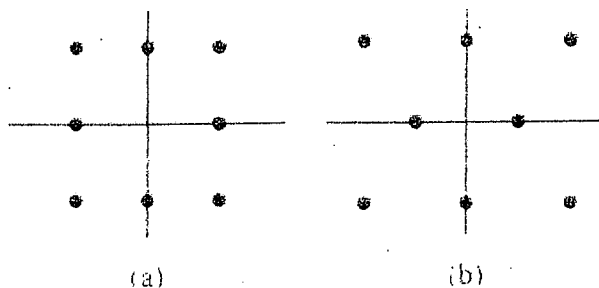

7. (15 points)  $M$ -ary PAM signals are represented geometrically as  $M$  one-dimensional signal points with value

$$s_m = \sqrt{\frac{1}{2} \varepsilon_g} A_m, \quad m = 1, 2, \dots, M$$

where  $\varepsilon_g$  is the energy of the basic signal pulse  $g(t)$ . The amplitude values may be expressed as

$$A_m = (2m - 1 - M)d, \quad m = 1, 2, \dots, M$$

where the Euclidean distance between adjacent signal points is  $d\sqrt{2\varepsilon_g}$ . Assuming equally probable signals:

(a) (5 points) Find the average energy.

(b) (5 points) Calculate the average probability of a symbol error.

(c) (5 points) Find the probability of a symbol error for rectangular  $M$ -ary QAM. ( $M = 2^k$ ,  $k$  is even)

Hint:  $\sum_{m=1}^M m = \frac{M(M+1)}{2}$ ;  $\sum_{m=1}^M m^2 = \frac{M(M+1)(2M+1)}{6}$ .

8. (10 points) Fourier Transform

(a) (5 points) Show that the spectrum of a real-valued signal exhibits conjugate symmetry, i.e., the amplitude spectrum is an even function of  $f$  and the phase spectrum is an odd function of  $f$ .

(b) (5 points) Given  $G(f) = \int_{-\infty}^{\infty} g(t) \exp(-j2\pi ft) dt$ , i.e.,  $G(f)$  is the Fourier transform of  $g(t)$ .

Show that  $\int_{-\infty}^{\infty} g(\tau) d\tau \Leftrightarrow \frac{1}{j2\pi f} G(f) + \frac{G(0)}{2} \delta(f)$ .