

# 國立中山大學九十二學年度碩士班招生考試試題

科目：工程數學(甲) (電機工程學系碩士班 甲.丙選.丁.戊組)

共 1 頁 第 頁

1. (20%) A periodic function with a period 2 is defined by  $x(t) = |t-1|$ ,  $0 \leq t \leq 2$ . Expand  $x(t)$  in Fourier series

$$x(t) = \sum_{k=-\infty}^{\infty} X[k] e^{jk\omega_0 t} = a_0 + \sum_{k=1}^{\infty} [a_k \cos(k\omega_0 t) + b_k \sin(k\omega_0 t)], \text{ where } \omega_0 \text{ is the fundamental}$$

angular frequency. Determine

- (a)  $X[k]$  (5pts),  
 (b)  $a_k$  and  $b_k$ ,  $k=1,2,3,\dots$  (10pts),  
 (c)  $\sum_{k=1}^{\infty} a_k \cos(\frac{1}{2}k\omega_0)$ . (5pts)
2. (15%) In the following  $\vec{c}$  is an arbitrary constant vector.

(a) Show that if  $\vec{c} \cdot \vec{A} = \vec{c} \cdot \vec{B}$ , we have  $\vec{A} = \vec{B}$ . (5pts)

(b) Prove  $\int_V \nabla \times \vec{F} dv = \oint_S d\vec{s} \times \vec{F}$ , where the surface  $S$  encloses the volume  $V$ . Hint:

Apply divergence theorem to  $\nabla \cdot (\vec{F} \times \vec{c})$ .

3. (15%) Let  $L$  be the operator on  $P_3$ , the set of all polynomials with degree less than 3, defined by

$$L(p(x)) := xp'(x) + p''(x).$$

- (a) (6%) Find the matrix  $A$  representing  $L$  with respect to the ordered basis  $[1, x, x^2]$ .  
 (b) (9%) Let  $p(x) = a_0 + a_1 x + a_2 (1+x^2)$ , where  $a_0, a_1$ , and  $a_2$  are arbitrary real numbers. Please find the polynomial  $L^n(p(x))$  in terms of  $a_0, a_1, a_2$ , and  $n$ .

4. (15%) Let  $A \in \mathbb{R}^{m \times n}$ ,  $B \in \mathbb{R}^{n \times r}$ , and  $C = AB$ .

(a) (6%) Show that if  $A$  and  $B$  both have linearly independent column vectors, then the column vectors of matrix  $C$  will also be linearly independent.

(b) (9%) Is the converse statement "if all columns of matrix  $C$  are linearly independent, then  $A$  and  $B$  both have linearly independent column vectors" also true? Prove it if your answer is YES. Otherwise, give a counter example to show that it is WRONG.

5. (15%) Find the general solution of the following differential equation:

$$e^x dx + (e^x \cot y + 2y \csc y) dy = 0.$$

6. (10%) (a) Find the Laplace transform of the following function:

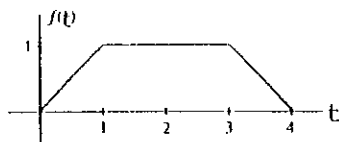

- (10%) (b) Find the inverse Laplace transform of the following function:

$$\frac{s^2 - 4}{(s^2 + 4)^2}$$

# 國立中山大學九十二學年度碩士班招生考試試題

科目：工程數學(乙) (電機工程學系碩士班 乙組)

共 1 頁 第 頁

1. (10%) A periodic function with a period 2 is defined by  $x(t) = |t-1|$ ,  $0 \leq t \leq 2$ . Expand  $x(t)$  in Fourier series

$$x(t) = \sum_{k=-\infty}^{\infty} X[k] e^{jk\omega_0 t} = a_0 + \sum_{k=1}^{\infty} [a_k \cos(k\omega_0 t) + b_k \sin(k\omega_0 t)], \text{ where } \omega_0 \text{ is the fundamental}$$

angular frequency. Determine

- (a)  $X[k]$  (5pts),
- (b)  $\sum_{k=1}^{\infty} a_k \cos(\frac{1}{2} k\omega_0)$ . (5pts)
2. (15%) In the following  $\vec{c}$  is an arbitrary constant vector.
- (a) Show that if  $\vec{c} \cdot \vec{A} = \vec{c} \cdot \vec{B}$ , we have  $\vec{A} = \vec{B}$ . (5pts)
- (b) Prove  $\int_V \nabla \times \vec{F} dv = \oint_S d\vec{s} \times \vec{F}$ , where the surface  $S$  encloses the volume  $V$ . Hint:

Apply divergence theorem to  $\nabla \cdot (\vec{F} \times \vec{c})$ .

3. (20%) Let  $L$  be the operator on  $P_2$ , the set of all polynomials with degree less than 2, defined by

$$L(p(x)) := 1 + x + (x+5)p'(x).$$

- (a) (6%) Find the matrix  $A$  representing  $L$  with respect to the ordered basis  $E := [1, x]$ .
- (b) (14%) If  $p(x) = c_0 + c_1 x$ , where  $c_0$  and  $c_1$  are any real numbers, then  $L^n(p(x))$  lies also in  $P_2$ . Let's denote  $L^n(p(x)) := \alpha + \beta x$ . Please find  $\alpha$  and  $\beta$  in terms of  $c_0$ ,  $c_1$ , and  $n$ .

4. (20%) Let  $A \in \mathbb{R}^{n \times n}$ ,  $B \in \mathbb{R}^{n \times r}$ , and  $C = AB$ .

- (a) (12%) Is the statement "if all the columns of matrix  $C$  are linearly independent, then  $A$  and  $B$  both have linearly independent column vectors" true? Prove it if your answer is YES. Otherwise, give explanations, based on the knowledge of linear algebra instead of explaining by a counter example, of why you think it is WRONG.
- (b) (8%) Is the statement "if  $A$  and  $B$  both have linearly independent column vectors, then all the columns of matrix  $C$  are linearly independent" true? Prove it if your answer is YES. Otherwise, give explanations, based on the knowledge of linear algebra instead of explaining by a counter example, of why you think it is WRONG.

5. (15%) Find the general solution of the following differential equation:

$$e^x dx + (e^x \cot y + 2y \csc y) dy = 0.$$

6. (10%) (a) Find the Laplace transform of the following function :

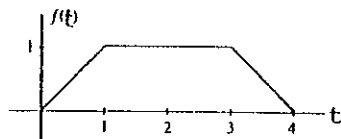

- (10%) (b) Find the inverse Laplace transform of the following function :

$$\frac{s^2 - 4}{(s^2 + 4)^2}$$

(1).

- (a) For the circuit shown in the right, find  $I_{O1}$  and  $I_{O2}$  in terms of  $I_{REF}$  and  $\beta$ . Assume all transistors to be matched with current gain  $\beta$ . 10%

- (b) Use this idea to design a circuit that generates currents of 1, 2, and 4 mA using a reference current source of 7mA. What are the actual values of the currents generated for  $\beta = 50$ ? 10%

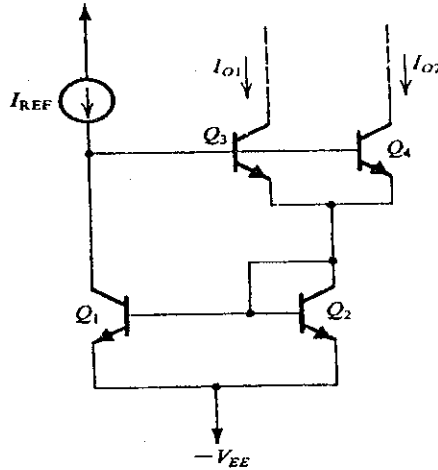

(2). For the basic gate circuit shown in the below, please answer the following questions.

- (a) What is the logic family of the circuit shown? 4%  
 (b) What are the logical functions of  $Output_1$  and  $Output_2$ ? 4%  
 (c) Assuming that the voltage drop across each of  $D_1$ ,  $D_2$ , and the base-emitter junction of  $Q_1$  is 0.75V, calculate the value of  $V_R$ . Neglect the base current of  $Q_1$ . 4%  
 (d) As in (c) with the input terminals  $A$  and  $B$  left open, find the current  $I_E$  through  $R_E$ . 4%  
 (e) As in (d) please also find the voltages at the  $Output_1$  and  $Output_2$ . 4%

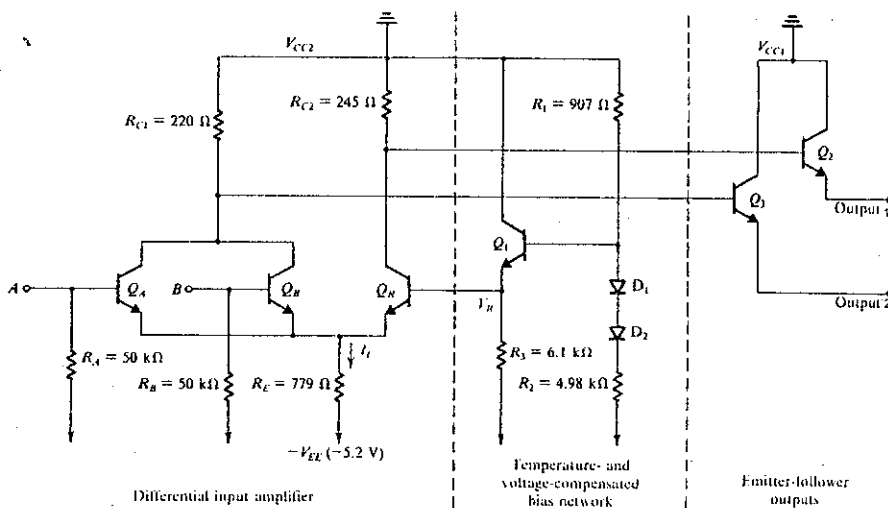

- (3). Design the circuit shown in the right (i.e. find the values for  $R_C$  and  $R_E$ ) to establish a collector current of 1mA and a reverse bias on the collector-base junction of 4V. Assume  $\alpha \cong 1$  and  $V_E \cong 0.7V$ . 20%
- (4). (a) What is the circuit as shown in the below? 5%  
 (b) Derive the transfer function of  $v_o$  over  $v_i$ . 5%  
 (c) Use the data of Table 1 shown in below to design the circuit in (a) to realize an all-pass filter with  $\omega_0$  rad/s,  $Q = 5$ , and flat gain = 1. Use  $C = 10nF$  and  $r = 10k\Omega$ . (i.e. to find the values for  $R$ ,  $QR$ ,  $C_1$ ,  $R_1$ ,  $R_2$  and  $R_3$ ). 10%

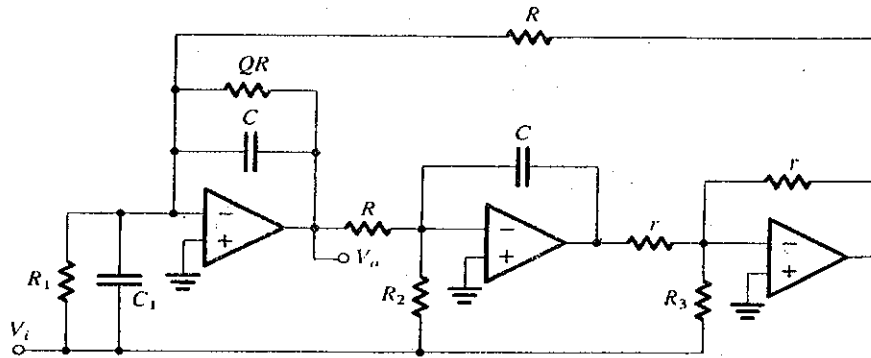
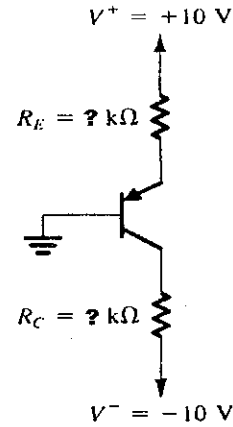

Table 1 DESIGN DATA FOR THE CIRCUIT

All cases	$C = \text{arbitrary}, R = 1/\omega_0 C, r = \text{arbitrary}$
LP	$C_1 = 0, R_1 = \infty, R_2 = R/\text{dc gain}, R_3 = \infty$
Positive BP	$C_1 = 0, R_1 = \infty, R_2 = \infty, R_3 = QR/\text{center-frequency gain}$
Negative BP	$C_1 = 0, R_1 = QR/\text{center-frequency gain}, R_2 = \infty, R_3 = \infty$
HP	$C_1 = C \times \text{high-frequency gain}, R_1 = \infty, R_2 = \infty, R_3 = \infty$
Notch (all types)	$C_1 = C \times \text{high-frequency gain}, R_1 = \infty,$ $R_2 = R(\omega_0/\omega_n)^2/\text{high-frequency gain}, R_3 = \infty$
AP	$C_1 = C \times \text{flat gain}, R_1 = \infty, R_2 = R/\text{gain}, R_3 = QR/\text{gain}$

- (5). (a) Draw and show the configuration of the four types of feedback design known to be used in an amplifier. 10%  
 (b) To increase the input resistance  $R_i$  of an amplifier, what type of feedback design should be used? Why? 5%  
 (c) To decrease the output resistance  $R_o$  of an amplifier, what type of feedback design should be used? Why? 5%

- 1) Describe and explain : how to obtain the value of energy gap of intrinsic semiconductor? ( assume the  $E_g$  value is independent on temperature) (10%)
- 2) Explain that the donor impurity atom has an energy level closing to conduction band.(10%)
- 3) Under a special condition, the Boron doped Si semiconductor,  $N_a=10^{16} \text{ cm}^{-3}$  shows an intrinsic property. What condition can match above description?. (15%)  
( Boron : ionization energy=0.045 eV,  $m_p^*=0.56 m_0$  ;  $m_n^*=1.08 m_0$  ;  $E_g=1.1 \text{ eV}$ ; and  $N_c=2.8 \times 10^{19} \text{ cm}^{-3}$ ,  $N_v=1.04 \times 10^{19} \text{ cm}^{-3}$  at 300 k)
- 4) Describe “how to get the ideal diode” and explain “the difference between ideal diode and real diode”. (15%)
- 5) For an MOS capacitor with a p-type substrate, describe and explain ” the characteristics of the ideal low frequency capacitance versus gate voltage” (10%).
- 6) Describe and explain (1)the hot electron effect in the short channel MOS device, and (2)how to effectively solve this problem. (15%)
- 7) Describe and explain : the electron concentration and conductivity as a function of inverse temperature for a doped Si when  $N_d=10^{15} \text{ cm}^{-3}$  “. (15%)
- 8) Describe and explain : how to obtain (a) an Ohmic contact and (b) Schottky contact by using metal and n-type semiconductor.(10%)

1. (16%) Find the transfer function  $Y_2(s)/R_1(s)$  of the following system:

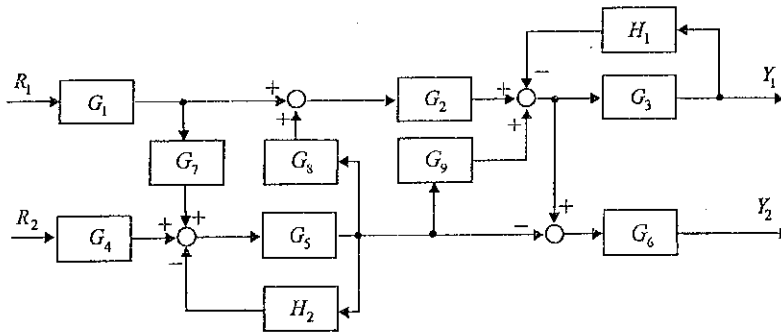

2. Consider the circuit shown below where  $u_1$  and  $u_2$  are voltage and current sources, respectively.  $R_1$  and  $R_2$  are nonlinear resistors with the following characteristics:

Resistor  $R_1$ :  $i_1 = v_1^2$

Resistor  $R_2$ :  $v_2 = (i_2 + 2)^2$

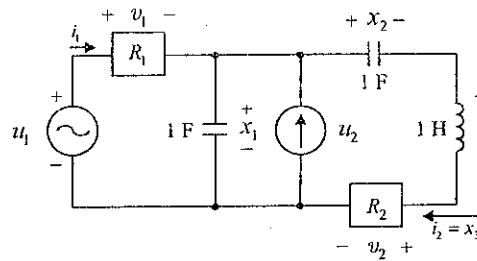

(a) (9%) Write the circuit equations in the form of  $\dot{x} = f(x, u)$ .

(b) (9%) Assume the circuit equations you derived in Part (a) are

$$\dot{x}_1 = (u_1 + x_1)^2 - u_2$$

$$\dot{x}_2 = x_1^2 x_3$$

$$\dot{x}_3 = x_1 u_2 - x_2 x_3 - (x_3 + 2)^2,$$

and we have a constant voltage source  $u_1 = 1$  and a constant current source  $u_2 = 0$ , i.e.,  $u_{10} = 1$ ,  $u_{20} = 0$ . Find the linearized equation in vector-matrix form around the point  $x_0 = [1 \ 0 \ -2]^T$ .

3. Determine the controllability and observability of the following systems, and explain.

(a) (8%)

$$\dot{x} = \begin{bmatrix} 1 & 1 & 0 & 0 & 0 \\ 0 & 1 & 0 & 0 & 0 \\ 0 & 0 & 1 & 0 & 0 \\ 0 & 0 & 0 & -4 & 1 \\ 0 & 0 & 0 & 0 & -4 \end{bmatrix} x + \begin{bmatrix} -2 \\ 9 \\ -5 \\ 1 \\ -3 \end{bmatrix} u, \quad y = [-2 \ 0 \ 3 \ 1 \ 7] x$$

(b)(8%)

$$\dot{x} = \begin{bmatrix} \lambda_1 & 1 & & & & \\ & \lambda_1 & & & & \\ & & \lambda_1 & & & \\ & & & \lambda_2 & 1 & \\ & & & & \lambda_2 & 1 \\ & & & & & \lambda_2 \end{bmatrix} x + \begin{bmatrix} 0 & 0 & 0 \\ 1 & 0 & 0 \\ 0 & 1 & 0 \\ 0 & 0 & 1 \\ 0 & 0 & 0 \\ 0 & 1 & 0 \\ 0 & 0 & 1 \end{bmatrix} u, \quad y = \begin{bmatrix} 1 & 1 & 2 & 0 & 1 & 2 & 0 \\ 1 & 0 & 1 & 2 & 0 & 1 & 0 \\ 1 & 0 & 2 & 3 & 0 & 2 & 0 \end{bmatrix} x$$

4. (17%) The block diagram of a linear control system is shown below, where  $r(t)$  is the reference input and  $n(t)$  is the disturbance.

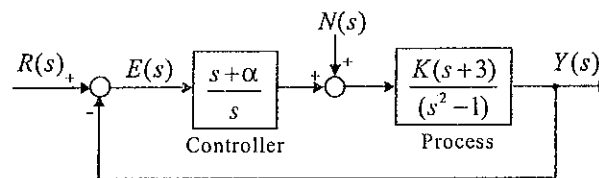

(a) Find the steady-state value of  $e(t)$  when  $n(t) = 0$  and  $r(t) = tu_s(t)$ . Find the conditions on the values of  $\alpha$  and  $K$  so that the solution is valid.

(b) Find the steady-state value of  $y(t)$  when  $r(t) = 0$  and  $n(t) = u_s(t)$ .

5. (17%) The block diagram of a feedback control system is shown as follows:

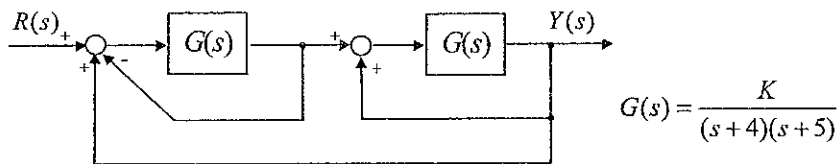

(a) Apply the Nyquist criterion to determine the range of  $K$  for stability.

(b) Check the answer obtained in part (a) with the Routh-Hurwitz criterion.

6. (16%) The block diagram of a control system with state feedback is shown as follows:

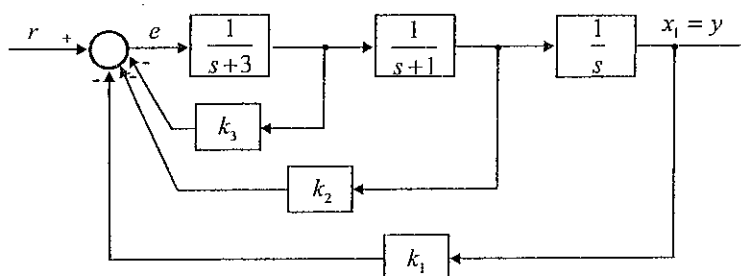

(a) Find the real feedback gains,  $k_1$ ,  $k_2$ , and  $k_3$  so that:

The steady-state error  $e_{ss}[e(t)]$  is the error signal] due to a step input is zero.

The complex roots of the characteristic equation are at  $-1 + j$  and  $-1 - j$ .

(b) Find the third root. Can all three roots be arbitrarily assigned while still meeting the steady-state requirement?



1. Explain the following terms or concept: (35%)
  - (a) The Well-Ordering Principle
  - (b) Diophantine Equation
  - (c) The Fundamental Theorem of Arithmetic
  - (d) The Pigeonhole Principle
  - (e) Euler Circuit
  - (f) Partially Ordered set (poset)
  - (g) Four-color Conjecture (for graph coloring)

2. Solve the recurrence relation: (10%)

$$a_{n+2} = 4a_{n+1} - 4a_n, n \geq 0, a_0 = 1, a_1 = 3$$

3. Let the graph  $G$  be as shown in Figure 1.  
Find the chromatic polynomial  $P(G, \lambda)$  and  
the chromatic number  $\chi(G, \lambda)$ . (15%)

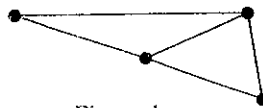

Figure 1.

4. Stirling number of the second kind,  $S(m, n)$ , is defined as

$$S(m, n) = \frac{1}{n!} \sum_{k=0}^n (-1)^k \binom{n}{n-k} (n-k)^m \quad \text{for } m \geq n$$

- (a) Use the concept of distribution to describe the meaning of this expression.  
(5%)
  - (b) Prove that  $S(m+1, n) = S(m, n-1) + n \cdot S(m, n)$  for  $1 < n \leq m$  and  $m, n \in \mathbb{Z}^+$   
(10%)
5. For  $n \in \mathbb{Z}^+$ , let  $\Phi(n)$  be the number of positive integers  $m$ , where  $1 \leq m < n$  and  $(m, n) = 1$ , i.e.,  $m, n$  are relatively prime. For example  $\Phi(2) = 1, \Phi(3) = 2$ . Please find  $\Phi(23100) = ?$  (10%)
  6. Use generating function to prove that "the number of partitions of a positive  $n$  into *distinct* summands equals the number of partitions of  $n$  into *odd* summands, when  $n \geq 1$ ". (15%)

國立中山大學九十二學年度碩士班招生考試試題

科目：資料結構 (電機系) (丙組選考)

共 2 頁 第 1 頁

1. (15 points) Suppose you want to determine whether a string  $x$  is in the language  $L$  or not, where  $L$ 
  - (a) (5 points)  $L = \{w \mid w \text{ is a string that contains equal numbers of } A\text{'s and } B\text{'s}\}$ .
  - (b) (5 points)  $L = \{w \mid w \text{ is a string of the form } A^n B^n \text{ for some } n \geq 0 \text{ and } n \in \mathbb{N}\}$ .
  - (c) (5 points)  $L = \{w\$w' \mid w \text{ is a string containing characters other than } \$, \text{ and } w' \text{ is the reverse of } w\}$ .

Please describe carefully and clearly (1) the data structures and (2) the algorithm you use for each case.

2. (15 points) Suppose you are given  $N$  unsorted, distinct data items. You want to arrange these items appropriately so that you can do search on them. Consider the following three implementations:
  - (a) (5 points) You use a linked list to store the data in an unsorted way.
  - (b) (5 points) You use an array to store the data in a sorted way.
  - (c) (5 points) You use a binary tree to store the data in a sorted way.

Please describe carefully and clearly (1) how you arrange these  $N$  items in a desired form with the specified data structures and (2) how you search for a given item  $x$  from your created data structures for each case.

3. (20 points) Suppose you are given 20 numbers in the following order:

60, 65, 25, 35, 90, 70, 30, 45, 95, 10, 50, 20, 55, 40, 100, 80, 5, 75, 15, 85.

Please answer the following questions:

- (a) (5 points) Create a binary search tree with these numbers presented in the order shown above. Draw the obtained tree.
- (b) (3 points) Do the inorder traversal on the obtained tree and list the numbers when they are encountered.
- (c) (3 points) Do the preorder traversal on the obtained tree and list the numbers when they are encountered.
- (d) (3 points) Do the postorder traversal on the obtained tree and list the numbers when they are encountered.
- (e) (3 points) Draw the resulting tree when another number 44 is inserted into the tree obtained in (a).
- (f) (3 points) Draw the resulting tree when the number 55 is deleted from the tree obtained in (a).

4. (15 points) Suppose you are given 20 numbers in the following order:

60, 65, 25, 35, 90, 70, 30, 45, 95, 10, 50, 20, 55, 40, 100, 80, 5, 75, 15, 85.

Please answer the following questions:

- (a) (5 points) Create a max heap with these numbers presented in the order shown above. Draw the obtained heap.
  - (b) (5 points) Create a min heap with these numbers presented in the order shown above. Draw the obtained heap.
  - (c) (2 points) Draw the resulting heap when another number 44 is inserted into the heap obtained in (a).
  - (d) (3 points) Draw the resulting heap when the number 55 is deleted from the heap obtained in (a).
5. (10 points) Consider the following two ways of handling collisions for hashing:
- (a) (5 points) Open addressing (or Linear probing).
  - (b) (5 points) Chaining.

If the hash function  $h(x) = x \bmod 7$  is used for resolving collisions, what does the hash table look like after the following insertions occur: 8, 10, 24, 15, 32, 17?

6. (10 points) Suppose we have an undirected graph  $G$ , with

$$V(G) = \{a, b, c, d, e, f, g, h, i, j\},$$

$$E(G) = \{(a, b), (b, c), (b, d), (c, e), (d, e), (d, f), (f, g), (f, h), (g, h), (h, i), (h, j)\}.$$

Please answer the following questions:

- (a) (5 points) Find the spanning tree of  $G$  using the depth-first strategy beginning with vertex  $a$ .
  - (b) (5 points) Find the spanning tree of  $G$  using the breadth-first strategy beginning with vertex  $a$ .
7. (15 points) Suppose you are given 20 numbers in the following order:

60, 65, 25, 35, 90, 70, 30, 45, 95, 10, 50, 20, 55, 40, 100, 80, 5, 75, 15, 85.

Please sort these numbers in ascending order using the following methods:

- (a) (5 points) Insertion sort.
- (b) (5 points) Quick sort.
- (c) (5 points) Merge sort.

Please show necessary details such that your procedures for the above cases are distinguishable. Answers without distinguishable details will not be acceptable.

[Problem 1] By Boolean algebra to determine and prove whether or not the following expressions are valid, i.e. whether the left- and right-hand sides represent same function. (10%)

a.  $x \cdot \bar{y} + \bar{x} \cdot y = \overline{\bar{x} \cdot \bar{y} + x \cdot y}$

b.  $x_1 \cdot \bar{x}_3 + x_2 \cdot \bar{x}_3 + x_1 \cdot x_3 + x_2 \cdot x_3 = \bar{x}_1 \cdot \bar{x}_2 + x_1 \cdot x_2 + x_1 \cdot \bar{x}_2$

[Problem 2] Design a circuit that implements the positive-edge-triggered Master-Slave D flip-flop with Clear and Preset using the basic gates such as NOT, AND, OR, NAND, and NOR. (20%)

[Problem 3] Given the positive-edge-triggered Master-Slave D flip-flop module(as Dff Symbol), the 2-to-1 multiplexer module( as MUX2to1 Symbol) and the basic gates such as NOT, AND, OR, NAND, and NOR, design the four-bit synchronous counter with the functions as follows: parallel load, up/down counter, shift left/ right and rotate left/ right. (20%)

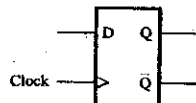

Dff Symbol

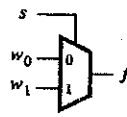

MUX2to1 Symbol

[Problem 4] Design a four-bit carry-lookahead adder using the basic gates such as NOT, AND, OR, NAND, NOR and XOR. (10%) By the four-bit carry-lookahead adder module (named CLA4), design a 16-bit carry-lookahead adder (5%). Let the basic gates take the same delay time as 1d. Determine the delay time of the critical path of the 16-bit carry-lookahead adder. (5%)

[Problem 5] Design a circuit with a clock input to generate the output signals A, B, C and D to control a four-phase stepper motor whose stepping waveform is described as table 1. (20%)

Table 1

step	Output signals			
	A	B	C	D
1	1	1	0	0
2	1	0	0	1
3	0	0	1	1
4	0	1	1	0
1	1	1	0	0

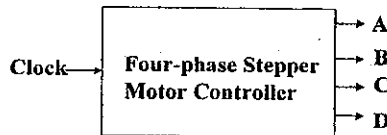

[Problem 6] In VHDL or Verilog HDL, write a 2-to-4 binary decoder. (10%)

1. (15%) Explain and identify two differences between the following terminology pairs.
  - (1) (5%) Shared-Memory multiprocessor vs Message-Passing multi-computer.
  - (2) (5%) VLIW architecture vs Superscalar architectures.
  - (3) (5%) Write-Through Cache vs Copy-Back Cache
  
2. (15%) A workstation uses a 500 Mhz processor to execute a given program mix with 10,000 instructions. Assume there are two processor cycles needed for every instruction decoding and execution. On average, each instruction will need two memory references. The ratio between memory cycle and processor cycle is 3.
  - (1) (5%) What is the effective CPI (Cycles per Instruction) of this computer?
  - (2) (5%) What is the MIPS (Million Instructions per Second) of this computer?
  - (3) (5%) What is the CPU throughput (in programs per second)?
  
3. (10%) If the last operation performed on a computer with an 8-bit word was an addition in which the two operands were  $-1$  (two's complement) and  $+1$ , what would be the value of the following flags?
  - (1) Carry; (2) Overflow; (3) Sign; (4) Even Parity; (5) Half-Carry.
  
4. (10%) Consider the following code:
 

```
FOR (i = 0; i < 20; i++)
    FOR (j = 0; j < 10; j++)
        a[i] = a[i] * j
```

  - (1) (5%) Given one example of the spatial locality in the code.
  - (2) (5%) Given one example of the temporal locality in the code.
  
5. (10%) Develop a Hamming Single Error Correction (SEC) code for a 16-bit data word.
  - (1) (5%) Generate the five check bits for the data word 010100000111001.
  - (2) (5%) Suppose when the data word is read from memory, the check bits are re-calculated to be 11001. What is the data word that was read from memory.
  
6. (10%) Consider an low-order memory interleaving design with 8 memory banks for a main memory system with 96 memory modules. Each module is assumed to have a capacity of 2 Mbytes. Specify the **address format** (that is, how many bits in Bank, Byte, and Module). Assume the machine is byte-addressable.
  
7. (10%) A computer has a cache, main memory, and a disk used for virtual memory. If a referenced word is in the cache, 20 ns are required to access it. If it is in main memory but not in the cache, 60 ns are needed to load it into the cache, and then the reference is started again. If the word is not in main memory, 12 ms are required to fetch the word from disk, followed by 60 ns to copy it to the cache, and then the reference is started again. The cache hit ratio is 0.9 and the main memory hit ratio is 0.6. What is the average time in ns required to access a referenced word on the system?
  
8. (10%) Assume the **exponent e** is constrained to lie in the range  $0 \leq e \leq X$ , with a bias of **q**, that the base is **b**, and that the significand is **p** digits in length.
  - (1) (5%) What are the largest and the smallest positive values that can be written?
  - (2) (5%) What are the largest and the smallest positive values that can be written as normalized floating-point numbers?
  
9. (10%) Draw a 3 stage, 8x8 **Omega MIN** (Multistage Interconnection Network) by using 2x2 switch modules as the building blocks. Determine whether the permutation (0, 7, 6)(1, 3)(5)(2, 4) will encounter any network blocking? If yes, identify the switch modules that have encountered collisions.
 

<Hint>: An **Omega network** employs **perfect shuffle** permutation between any two stages.

# 國立中山大學九十二學年度碩士班招生考試試題

科目： 電路學 (電機系丁組)

1. Derive the current response  $i_L(t)$  at the following circuit, and calculate  $i_L(\infty)$  (20%).

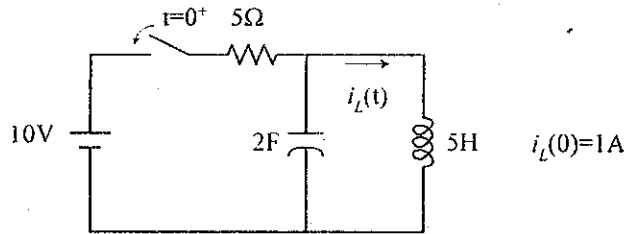

2. Derive the node-voltage equations of the following circuit and express them into vector form (20%).

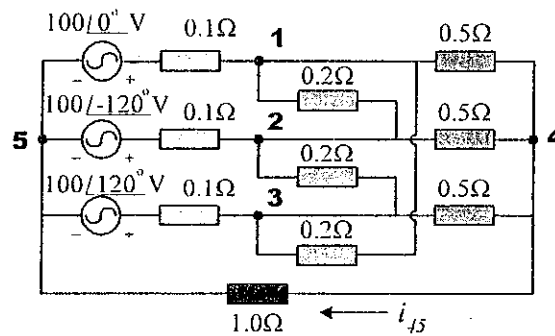

3. On the same circuit as shown in Problem #2, calculate the current flowing from point 4 to point 5 ( $i_{45}$ ), and the total power dissipated in the  $1\Omega$  resistor (20%).
4. For the following circuit, find the Norton's equivalent circuit as viewed from points A and B (20%).

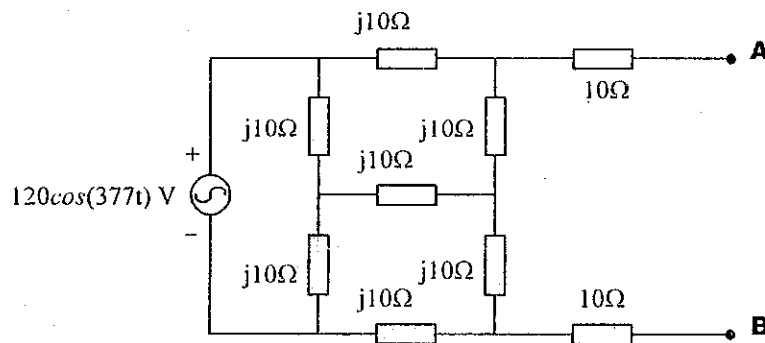

5. If all the diode elements are ideal (turned on when a positive voltage is applied) in the following circuit, calculate the averaged DC voltage output (20%).

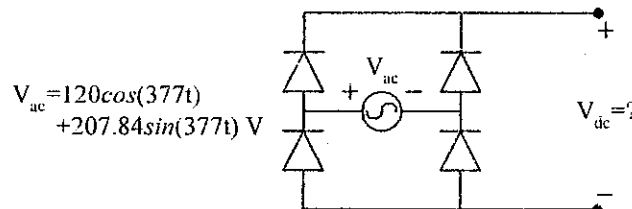

# 國立中山大學九十二學年度碩士班招生考試試題

科目：電力系統 (電機系丁組)

共 / 頁 第 / 頁

- (1)(a) Form the  $Z_{bus}$  for the circuit in Fig. 1. Determine the bus voltages of all nodes when  $V_3 = 1.2 \angle 0^\circ$ , and the load currents are  $I_{L1} = -j0.1$ ,  $I_{L2} = -j0.1$ ,  $I_{L3} = -j0.2$  and  $I_{L4} = -j0.2$  all in per unit. (15%)
- (b) If the load currents are neglected, find the magnitude of fault current and the post fault bus voltages with 3 $\Phi$  bolted short circuit at bus 2. (5%)

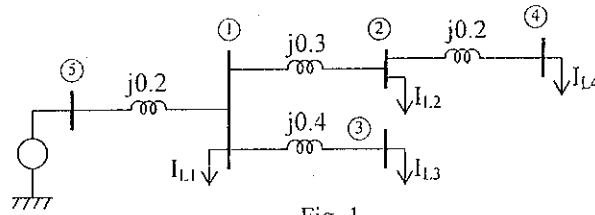

Fig. 1

- (2) In Fig. 2, Bus 1 is a slack bus with  $V_1 = 1.0 \angle 0^\circ$  p.u.. The line impedance is on a base of 100MVA. Using Newton-Raphson method, solve the voltage at bus 2 for one iteration with initial voltage  $V_2^{(0)} = 1.0 \angle 0^\circ$ . (25%)

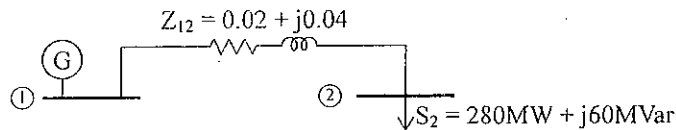

Fig. 2

- (3) For the system in Fig. 3, the ratings and reactance of the Generators and Transformers are

$G_1$  and  $G_2$ : 200MVA, 20KV,  $X_d'' = X_1 = X_2 = 30\%$ ,  $X_0 = 4\%$ ,  $X_n = 5\%$

$T_1$  and  $T_2$ : 100MVA, 20Y/345Y KV,  $X = 8\%$

Line ( $L_{23}$ ) reactance are  $X_1 = X_2 = 15\%$  with base of 100MVA, 345kV. Solve the fault current for bolted single line to ground fault at the middle of line  $L_{23}$ . (20%)

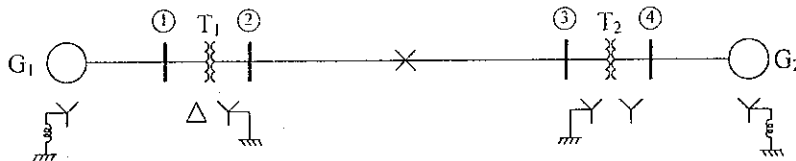

Fig. 3

- (4) For power system transient stability analysis. what is the swing equation and how it is applied to illustrate the equal area criterion to determine the critical clearing time for three phase fault. (15%)
- (5) The fuel cost functions in of \$/hr of two thermal plants are

$$C_1 = 320 + 6.2P_1 + 0.004P_1^2$$

$$C_2 = 200 + 6.0P_2 + 0.003P_2^2$$

where  $P_1, P_2$  are in MW with limits as follows.

$$50 \leq P_1 \leq 250$$

$$50 \leq P_2 \leq 350$$

The per unit system power loss on a 100MVA base is given by

$$P_{L(p.u.)} = 0.00625P_1 + 0.0125P_2$$

Solve the economic dispatch of the generators to serve the load of 400MW. (20%)

1. Consider two infinite plane current sheets of uniform current densities given by

$$\mathbf{J}_{s1} = -\mathbf{a}_x J_0 \cos \omega t \quad , \quad \text{at the } z = 0 \text{ plane}$$

$$\mathbf{J}_{s2} = -\mathbf{a}_x p J_0 \sin \omega t \quad , \quad \text{at the } z = d \text{ plane}$$

with  $f = 10^6$  MHz and  $p$  a constant, located in a medium characterized by  $\sigma = 10^{-3}$  S/m,  $\epsilon_r = 6$  and  $\mu_r = 1$ .

- (a) Find the minimum value of  $d$  ( $> 0$ ) and the corresponding value of  $p$  for which the fields in the region  $z < 0$  are zero.  
 (b) For the values of  $d$  and  $p$  found in (a), obtain the electric field intensity in the  $z > d$  region. (20%)

2. A space-charge density distribution is given by

$$\rho = \begin{cases} -\rho_0(1+x/d) & , \quad \text{for } -d < x < 0 \\ \rho_0(1-x/d) & , \quad \text{for } 0 < x < d \\ 0 & , \quad \text{otherwise} \end{cases}$$

where  $\rho_0$  is a constant. Obtain the solution for the potential  $V$  for all regions, assuming  $V = 0$  for  $x = 0$ . (20%)

3. A magnetic field is given in the  $xz$ -plane by

$$\mathbf{B} = \mathbf{a}_y B_0 \cos \pi(x - v_0 t) \quad \text{Wb/m}^2$$

Consider a rigid square loop located in the  $xz$ -plane with its vertices at  $(x, 0, 1)$ ,  $(x, 0, 2)$ ,  $(x+1, 0, 2)$ , and  $(x+1, 0, 1)$ .

- (a) Find the expression for the emf induced around the loop.  
 (b) What would be the induced emf if the loop is moving with the velocity  $\mathbf{v} = \mathbf{a}_x v_0$  m/s instead of being stationary? (20%)

4. An electromagnetic wave from an underwater source with perpendicular polarization is incident on a water-air interface at  $\theta_i = 30^\circ$ . Using  $\epsilon_r = 81$  and  $\mu_r = 1$  for water, find

- (a) critical angle  $\theta_c$ ,  
 (b) reflection coefficient  $\Gamma_{\perp}$ ,  
 (c) transmission coefficient  $\tau_{\perp}$ ,  
 (d) attenuation for each wavelength into the air. (20%)

5. Briefly answer the following questions. (5% each)

- (a) What is the skin effect of conductors? Describe your knowledge about it.  
 (b) Describe a Smith Chart as best as you can. Why is it still useful when we can just use computers to do the transmission line calculations?  
 (c) What is the meaning of the polarization of a plane wave?  
 (d) What is the dispersion effect for electromagnetic wave propagation? As far as you know, what are the factors that can cause the dispersion effect?



Linear Algebra

1. (20%) The trace of an  $n \times n$  matrix  $A$  is defined as the sum of its diagonal elements

$$\text{tr}(A) = \sum_{i=1}^n A_{ii}$$

- (a) (7%) Show that  $\text{tr}(AB) = \text{tr}(BA)$  for any  $n \times n$  matrices  $A$  and  $B$ .  
 (b) (5%) Prove that if matrix  $B$  is similar to matrix  $A$ , then  $\text{tr}(A) = \text{tr}(B)$ .  
 (c) (8%) Prove that the trace of a diagonalizable matrix is equal to the sum of all its eigenvalues. (Note: the eigenvalues are not necessarily distinct.)
2. (20%) A linear operator is defined as  $T: \mathbf{R}^3 \rightarrow \mathbf{R}^3$ ,  $T(x, y, z) = (2x + y, y - z, 2y + 4z)$ .
- (a) (6%) Find the characteristic polynomial  $\Delta(t)$  of  $T$ .  
 (b) (6%) Find the eigenvalues of  $T$ .  
 (c) (8%) For each of the eigenvalues found above, find a basis of eigenspace.

3. (8%)

- (a) (4%) Find the trace of the following operator on  $\mathbf{R}^3$ :

$$T(x, y, z) = (a_1x + a_2y + a_3z, b_1x + b_2y + b_3z, c_1x + c_2y + c_3z)$$

- (b) (4%) Find the determinant of the above linear operator  $T$ .

4. (20%) Let  $A = \begin{bmatrix} 1 & 1 \\ 0 & 1 \end{bmatrix}$  and  $B = \begin{bmatrix} 0 & -2 \\ 1 & 3 \end{bmatrix}$ .

- (a) (5%) Find  $A^n$ ?  
 (b) (5%) Find  $f(B)$  where  $f(t) = 2t^2 - 3t + 7$ . Is  $B$  a root of  $f(t)$ ?  
 (c) (10%) Find  $e^B$ .

5. (12%) Let  $T: V \rightarrow U$  be a linear transformation between vector spaces  $V$  and  $U$ .

- (a) (6%) Suppose that vectors  $v_1, \dots, v_n \in V$  have the property that their images  $T(v_1), \dots, T(v_n)$  are linearly independent. Show that the vectors  $v_1, \dots, v_n$  are also linearly independent.  
 (b) (6%) Let  $\{e_1, e_2, e_3\}$  be a basis of  $V$  and  $\{f_1, f_2\}$  a basis of  $U$ . Suppose

$$\begin{aligned} T(e_1) &= a_1f_1 + a_2f_2 \\ T(e_2) &= b_1f_1 + b_2f_2 \\ T(e_3) &= c_1f_1 + c_2f_2 \end{aligned}$$

and

$$A = \begin{bmatrix} a_1 & b_1 & c_1 \\ a_2 & b_2 & c_2 \end{bmatrix}$$

For any  $v \in V$ , show that  $A[v]_e = [T(v)]_f$ .

6. (20%)

- (a) (5%) Let  $V$  be an inner product space, and let  $B = \{e_1, \dots, e_n\}$  be a basis of  $V$ . Assume that matrix  $A$  represents the inner product on  $V$  with respect to the basis  $B$ . For any vectors  $u, v \in V$ , prove that  $\langle u, v \rangle = [u]^T A [v]$ , where  $[u]$  and  $[v]$  denote, respectively, the coordinate vectors of  $u$  and  $v$  relative to the basis  $B$ .
- (b) For the vector space  $V$  of polynomials  $f(t)$  and  $g(t)$  of degree  $\leq 2$  with inner product defined as  $\langle u, v \rangle = \int_{-1}^1 f(t)g(t)dt$ :
- (5%) Find  $\langle u, v \rangle$  where  $f(t) = t + 2$  and  $g(t) = t^2 - 3t + 4$ .
  - (5%) Find the matrix  $A$  of the inner product with respect to the basis  $\{1, t, t^2\}$  of  $V$ .
  - (5%) Verify that  $\langle f, g \rangle = [f]^T A [g]$  with respect to the basis  $\{1, t, t^2\}$ .

~End ~

1. Let  $\Gamma(\alpha)$  be a *gamma function*, which is defined by

$$\Gamma(\alpha) = \int_0^{\infty} x^{\alpha-1} e^{-x} dx$$

for  $\alpha > 0$ . It is known that the *gamma function* has the following properties, e.g.,  $\Gamma(\alpha) = (\alpha-1)\Gamma(\alpha-1)$ ,  $\Gamma(n+1) = n!$ ,  $\Gamma(1/2) = (\pi)^{1/2}$  and  $\Gamma(1) = 1$ . Let us consider the *random variable*  $X$  has a *gamma distribution* with *probability density function* to be defined by

$$f_X(x) = \begin{cases} \frac{1}{\beta^\alpha \Gamma(\alpha)} x^{\alpha-1} e^{-x/\beta}, & \text{if } x > 0 \\ 0, & \text{otherwise} \end{cases}$$

where  $\alpha > 0$  and  $\beta > 0$ .

- (a) For  $\alpha = 1/2$  and  $\beta = 2$ , please evaluate the *mean*  $\mu = E[X]$ , and *variance*  $\sigma_X^2 = E[(X-E[X])^2]$  (12%).
- (b) For  $\alpha = 1$  we have the so-called *exponential distribution*, again, find the *mean*  $\mu$  and  $\sigma_X^2$  for *random variable*  $X$  (8%).

2. Consider two *independent identical distribution (i.i.d) random variables*,  $X$  and  $Y$ . (a) Find the *probability density function* of *random variable*,  $Z = X + Y$  (8%) (b) If the *probability density function* of  $X$  and  $Y$  are with

$$f_X(x) = f_Y(x) = \frac{1}{a} \text{rect}\left(\frac{x}{a}\right) = \begin{cases} \frac{1}{a}, & -\frac{a}{2} \leq x \leq \frac{a}{2} \\ 0, & \text{otherwise} \end{cases}$$

compute the *probability density function* of  $Z$  (12%).

3. Let  $X$  be a *random variable* and  $A = \{X \leq b\}$ . (a) Find the *conditional probability distribution function*,  $F_{X|A}(x | A)$  (10%) and (b) find the *conditional density function*  $f_{X|A}(x | A)$ . (5%)

4. An electrical system consists of four components as illustrated in Figure P4. The system works if components  $A$  and  $B$  work and either of the components  $C$  or  $D$  work. The reliability (probability of working) of each component is also shown in Figure P4. Find the probability that (a) the entire system works, (10%) and (b) the component  $C$  does not work, given that the entire system works. Assume that four components work independently. (10%).

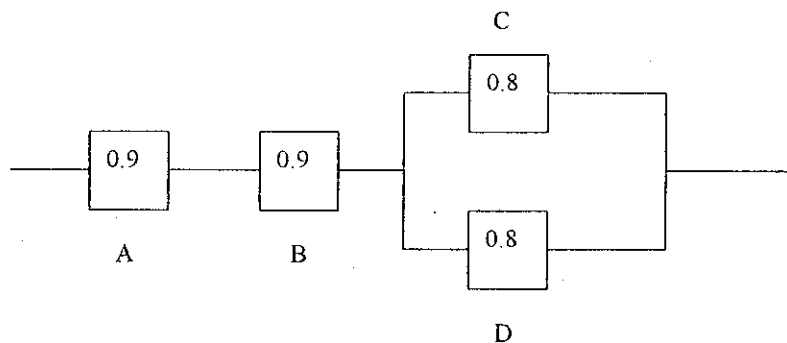

Figure P4 An electrical system for Problem 4.

5. Consider the following *joint probability density function* of the random variables  $X$  and  $Y$ :

$$f_{X,Y}(x,y) = \begin{cases} \frac{3x-y}{9}, & 1 < x < 3, \quad 1 < y < 2 \\ 0 & , \textit{otherwise} \end{cases}$$

- (a) Find the *marginal density functions* of  $X$  and  $Y$ . (5%)  
(b) Are  $X$  and  $Y$  independent? (5%)  
(c) Find  $P(X > 2)$ . (5%)
6. A zero-mean normal (*Gaussian*) random vector  $\mathbf{X} = (X_1, X_2)^T$  has *covariance matrix*  $\mathbf{K}$  given by

$$\mathbf{K} = \begin{bmatrix} 3 & -1 \\ -1 & 3 \end{bmatrix}$$

- Find a transformation  $\mathbf{Y} = \mathbf{D}\mathbf{X}$  such that  $\mathbf{Y} = (Y_1, Y_2)^T$  is a normal random vector with uncorrelated (and therefore *independent*) components of unity variance (10%).

計分說明： 本題計分將採用一種新創的"市場需求調整計分法"，即計分高低(價值)與獲解率(市場需求率之倒數，愈易獲解，市場上需求愈低)成反比。所以考生除了要把握多數人會的題目外，還要著重於自己獨特的能力，即別人不容易會的問題。在入學徵才錄取率不高的情況下，希望考生能發揮出自己卓越的特點。

你的得分( $S_1, S_2, S_3, \dots$ )公式計算如下：令 $R_1, R_2, R_3, \dots$ 為小題各自原始分數給分範圍， $R'_1, R'_2, R'_3, \dots$ 為依市場需求調整後的分數給分範圍， $M_1, M_2, M_3, \dots$ 為小題各自的原始平均得分， $S_1, S_2, S_3, \dots$ 為小題各自原始得分：

$$\text{則 } S'_i = S_i \times \frac{R'_i}{R_i}$$

而 $R'_1, R'_2, R'_3, \dots$ 的計算，在 $M_1, M_2, M_3, \dots$ 的各小題平均分數算出後，

$$\text{依據 } R'_1 : R'_2 : R'_3, \dots = \frac{R_1}{M_1} : \frac{R_2}{M_2} : \frac{R_3}{M_3}, \dots \text{ 得到，且 } R'_1 + R'_2 + R'_3, \dots = 100$$

注意 $R_1, R_2, R_3, \dots$ 的原始範圍可以任意設定，為著讓考生易所依循，我仍可以做一次

不必要的設定： $R_1 = R_2 = R_3, \dots = \frac{100}{n}$  ← 每題計分

1. As illustrated in the following plot, (a) is the carrier wave and (b) is the sinusoidal modulating signal please explain

- (1) Which is the phase modulated signal?
- (2) Which is the frequency modulated signal?

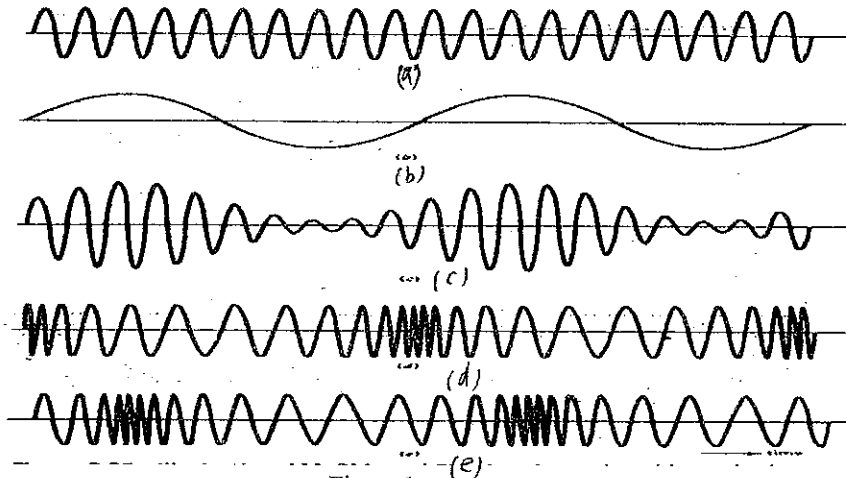

Figure 1

2. As illustrated in Figure 2, (a) is the spectrum of the baseband signal prove (not by memorizing the formula) that the spectrum of the DSB-SC modulated wave is (b).

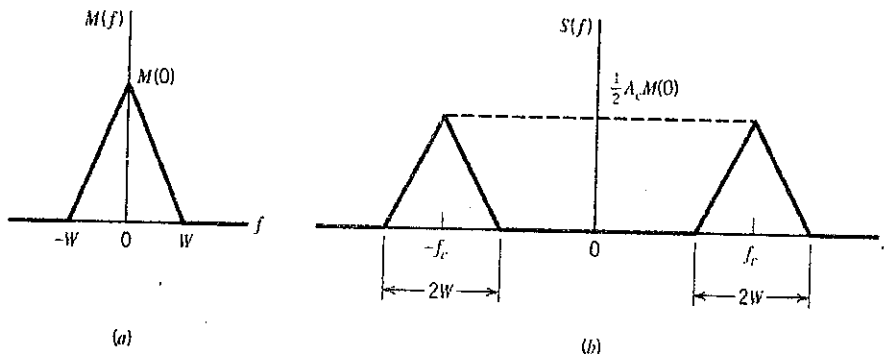

Figure 2.

3. The realization of the modulation system in (b) can be understood by (a).  
 (1) What term in (a) has a very simple relation with  $g_i(t)$  in (b)? And what is this relation?  
 (2) If (b) is a realization of the SSB modulation system, what should be modified in (a)?

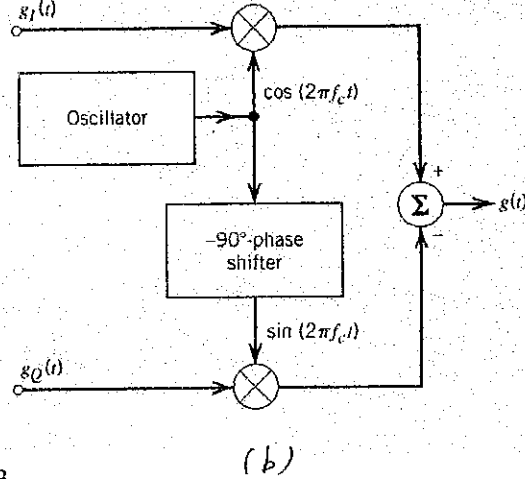
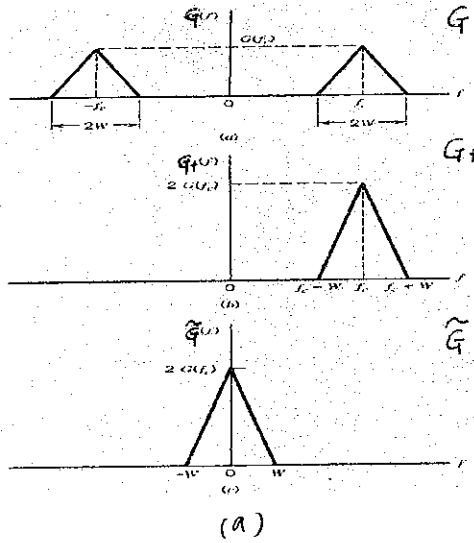

Figure 3.

4. FM demodulation is demonstrated in Figure 4. Please explain whether the block of  $\sin(\cdot)$  in the diagram (b) should be removed. (To answer this problem, you must understand the relation functionally between diagrams (a) and (b).)

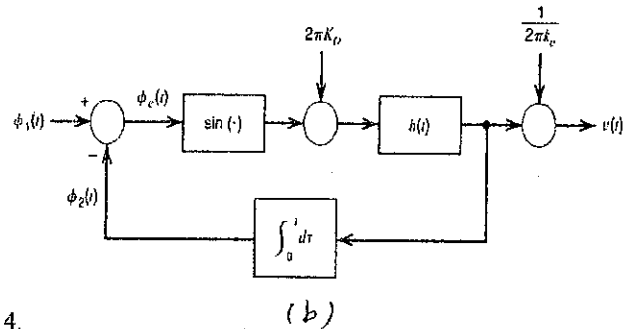
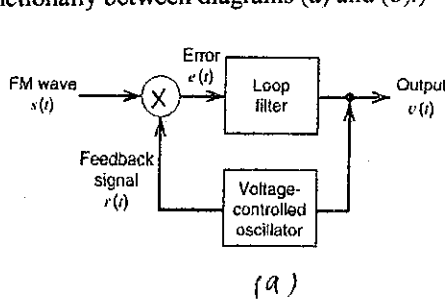

Figure 4.

5. Prove diagrams (a) and (b) in Figure 5 are equivalent for matched filter receivers.

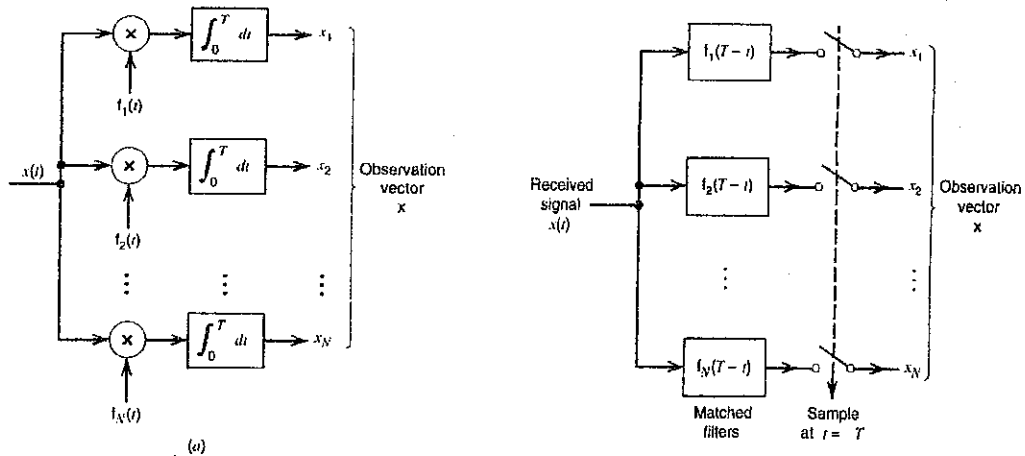

Figure 5

6. (1) what modulation system is shown in Figure 6?  
 (2) Please sketch the block diagram of the receiver for this system.

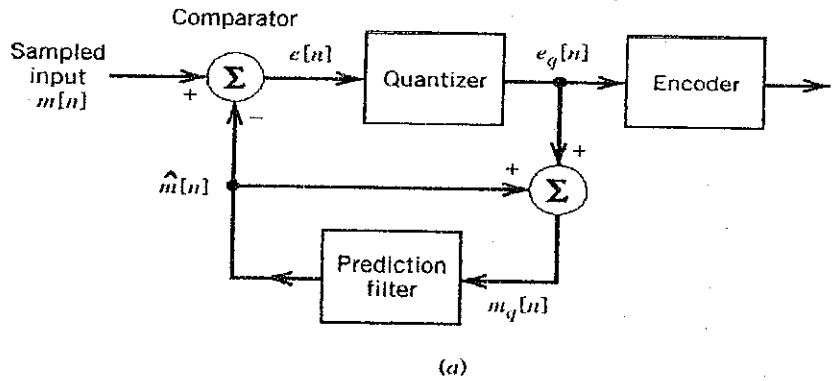

Figure 6

7. Intersymbol interference can be solved by the system schematics in Figure 7. Therefore, (1) which of the following blocks are assumed known?  
 (2) Which of the following blocks are the designed objects?

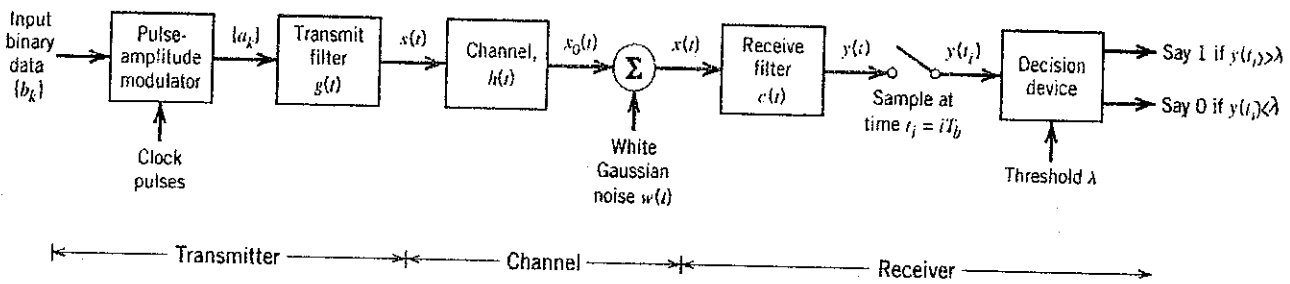

Figure 7.