

國立中山大學 115 學年度 碩士班考試入學招生考試試題

科目名稱：電子學【電機系碩士班乙組選考、戊組選考、通訊所碩士班乙組選考、電波聯合碩士班選考】

— 作答注意事項 —

考試時間：100 分鐘

- 考試開始鈴響前不得翻閱試題，並不得書寫、劃記、作答。請先檢查答案卷（卡）之應考證號碼、桌角號碼、應試科目是否正確，如有不同立即請監試人員處理。
- 答案卷限用藍、黑色筆(含鉛筆)書寫、繪圖或標示，可攜帶橡皮擦、無色透明無文字墊板、尺規、修正液（帶）、手錶(未附計算器者)。每人每節限使用一份答案卷，請衡酌作答。
- 答案卡請以 2B 鉛筆劃記，不可使用修正液（帶）塗改，未使用 2B 鉛筆、劃記太輕或污損致光學閱讀機無法辨識答案者，後果由考生自負。
- 答案卷（卡）應保持清潔完整，不得折疊、破壞或塗改應考證號碼及條碼，亦不得書寫考生姓名、應考證號碼或與答案無關之任何文字或符號。
- 可否使用計算機請依試題資訊內標註為準，如「可以」使用，廠牌、功能不拘，唯不得攜帶書籍、紙張（應考證不得做計算紙書寫）、具有通訊、記憶、傳輸或收發等功能之相關電子產品或其他有礙試場安寧、考試公平之各類器材入場。
- 試題及答案卷（卡）請務必繳回，未繳回者該科成績以零分計算。
- 試題採雙面列印，考生應注意試題頁數確實作答。
- 違規者依本校招生考試試場規則及違規處理辦法處理。

國立中山大學 115 學年度碩士班考試入學招生考試試題

科目名稱：電子學【電機系碩士班乙組選考、戊組選考、通訊所碩士班乙組選考、電波聯合碩士班選考】題號：431005

※本科目依簡章規定「可以」使用計算機（廠牌、功能不拘）（問答申論題） 共 2 頁第 1 頁

1. (30 pt) For the circuit in Fig. 1, it is required to determine the value of the voltage V_{BB} that results in the transistor operating
- in the active mode with $V_{CE} = 5\text{ V}$ (10 pt)
 - at the edge of saturation (10 pt)
 - deep in saturation with $\beta_{\text{forced}} = 10$ (10 pt)
- For simplicity, assume that V_{BE} remains constant at 0.7 V . The transistor β is specified to be 50.

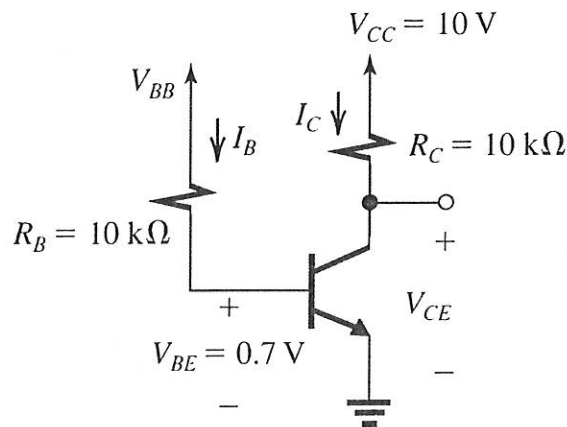

Figure 1.

2. (20 pt) For the circuit in Fig. 2, assume that $\beta_{\text{min}} = 30$, and find (a) V_E (5 pt), (b) V_B (5 pt), (c) I_{C1} (5 pt), and (d) I_{C2} (5 pt).

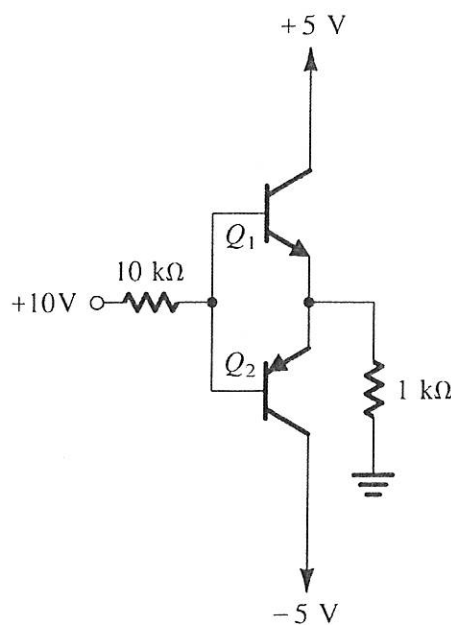

Figure 2.

國立中山大學 115 學年度碩士班考試入學招生考試試題

科目名稱：電子學【電機系碩士班乙組選考、戊組選考、通訊所碩士班乙組選考、電波聯合碩士班選考】題號：431005

※本科目依簡章規定「可以」使用計算機（廠牌、功能不拘）（問答申論題） 共 2 頁第 2 頁

3. (20 pt) For the circuit in Fig. 3, a full-wave bridge-rectifier circuit with a 1-k Ω load operates from a 120-V (rms) 60-Hz household supply through a 12-to-1 step-down transformer having a single secondary winding. It uses four diodes, each of which can be modeled to have a 0.7-V drop for any current. (a) What is the peak value of the rectified voltage across the load? (5 pt) (b) For what fraction of a cycle does each diode conduct? (5 pt) (c) What is the average voltage across the load? (5 pt) (d) What is the average current through the load? (5 pt)

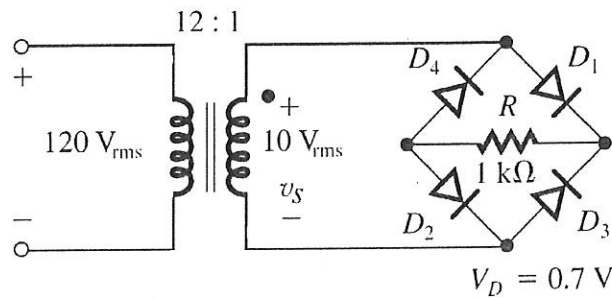

4. (30 pt) In the circuit of Fig. 4, the NMOS transistor has $|V_t| = 0.9$ V, and $V_A = 50$ V, and operates with $V_D = V_{GS} = 2$ V. (a) What is the voltage gain v_o/v_i ? (10 pt) (b) What does V_D become when I increase to 1 mA? (10 pt) And (c) what is the new gain? (10 pt)

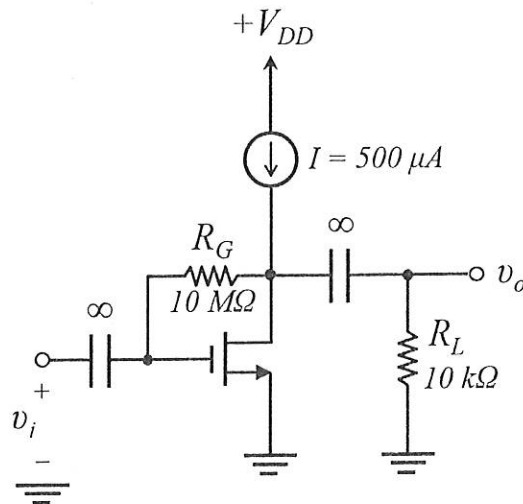

國立中山大學 115 學年度 碩士班考試入學招生考試試題

科目名稱：通訊理論【電機系碩士班戊組選考、通訊所碩士班甲組、乙組選考、電波聯合碩士班選考】

— 作答注意事項 —

考試時間：100 分鐘

- 考試開始鈴響前不得翻閱試題，並不得書寫、劃記、作答。請先檢查答案卷（卡）之應考證號碼、桌角號碼、應試科目是否正確，如有不同立即請監試人員處理。
- 答案卷限用藍、黑色筆(含鉛筆)書寫、繪圖或標示，可攜帶橡皮擦、無色透明無文字墊板、尺規、修正液（帶）、手錶(未附計算器者)。每人每節限使用一份答案卷，請衡酌作答。
- 答案卡請以 2B 鉛筆劃記，不可使用修正液（帶）塗改，未使用 2B 鉛筆、劃記太輕或污損致光學閱讀機無法辨識答案者，後果由考生自負。
- 答案卷（卡）應保持清潔完整，不得折疊、破壞或塗改應考證號碼及條碼，亦不得書寫考生姓名、應考證號碼或與答案無關之任何文字或符號。
- 可否使用計算機請依試題資訊內標註為準，如「可以」使用，廠牌、功能不拘，唯不得攜帶書籍、紙張（應考證不得做計算紙書寫）、具有通訊、記憶、傳輸或收發等功能之相關電子產品或其他有礙試場安寧、考試公平之各類器材入場。
- 試題及答案卷（卡）請務必繳回，未繳回者該科成績以零分計算。
- 試題採雙面列印，考生應注意試題頁數確實作答。
- 違規者依本校招生考試試場規則及違規處理辦法處理。

國立中山大學 115 學年度碩士班考試入學招生考試試題

科目名稱：通訊理論【電機系碩士班戊組選考、通訊所碩士班甲組、乙組選考、電波聯合碩士班選考】題號：437002

※本科目依簡章規定「可以」使用計算機（廠牌、功能不拘）（混合題）

共 4 頁第 1 頁

一、選擇題(單選，計分方式:不倒扣，答對得該題全部分數，答錯及未作答得零分)

1. (5%) Suppose a communication channel has bandwidth W . Let the symbol (sampling) interval be $t_s = \frac{1}{W}$. Which of the following pulse waveforms does not satisfy the ISI-free (Nyquist) criterion?
 - (A) $p_1(t) = 2W \operatorname{sinc}^2(2Wt) + W \operatorname{sinc}(Wt)$
 - (B) $p_2(t) = 4W \operatorname{sinc}(4Wt) - W \operatorname{sinc}^2(Wt)$
 - (C) $p_3(t) = 2W \operatorname{sinc}(Wt) \cos(2\pi Wt)$
 - (D) $p_4(t) = 2W \operatorname{sinc}^2(2Wt) - W \operatorname{sinc}^2(Wt)$
 - (E) None of the above

2. (5%) An M -ary communication system transmits at a rate of 2000 symbols per second. What is the equivalent bit rate in bits per second for $M = 16$?
 - (A) 4000
 - (B) 6000
 - (C) 8000
 - (D) 10000
 - (E) None of the above

3. (5%) Consider a 3-ary communication system in which each transmitted message is chosen from one of three symbols, m_{-1} , m_0 , and m_1 . These symbols are transmitted using the waveforms $-p(t)$, 0 , and $p(t)$, respectively, where the pulse $p(t)$ has duration T_M . At the receiver, a matched filter matched to $p(t)$ is employed. Let r denote the output of the matched filter sampled at time T_M . Assume that the messages are quiprobable, i.e., $P(m_{-1}) = P(m_0) = P(m_1)$. The energy of the pulse $p(t)$ is E_p and the channel noise is additive white Gaussian noise (AWGN) with two-sided power spectral density $N_0/2$. Determine the symbol error probability P_e using the optimum decision thresholds. (The Q-function is defined as $Q(x) = \frac{1}{\sqrt{2\pi}} \int_x^\infty e^{-z^2/2} dz$.)
 - (A) $P_e = \frac{4}{3} Q\left(\sqrt{\frac{E_p}{2N_0}}\right)$
 - (B) $P_e = \frac{1}{3} Q\left(\sqrt{\frac{E_p}{2N_0}}\right)$
 - (C) $P_e = Q\left(\sqrt{\frac{3E_p}{2N_0}}\right)$
 - (D) $P_e = Q\left(\sqrt{\frac{E_p}{N_0}}\right)$
 - (E) None of the above

4. (5%) Let $g(t)$ be a signal with Fourier transform $G(f)$. Define $G_1(t)$ as the inverse Fourier transform of the frequency-domain function $g(af - f_0)$. Which of the following expressions correctly gives $G_1(t)$?
 - (A) If $a > 0$, $G_1(t) = \frac{1}{a} G(-t/a) e^{j2\pi f_0 t/a}$
 - (B) If $a < 0$, $G_1(t) = \frac{1}{a} G(t/a) e^{j2\pi f_0 t/a}$
 - (C) If $a = 0$, $G_1(t) = g(f_0) \delta(t)$

試題請隨卷繳回，請留意背面是否有題

國立中山大學 115 學年度碩士班考試入學招生考試試題

科目名稱：通訊理論【電機系碩士班戊組選考、通訊所碩士班甲組、乙組選考、電波聯合碩士班選考】題號：437002

※本科目依簡章規定「可以」使用計算機（廠牌、功能不拘）（混合題）

共 4 頁 第 2 頁

- (D) If $a = 0$, $G_1(t) = g(1/f_0)\delta(t)$
 (E) None of the above

5. (5%) Consider a narrowband FM signal that can be approximated by

$$s(t) \approx A_c \cos(2\pi f_c t) - \beta A_c \sin(2\pi f_m t) \sin(2\pi f_c t),$$

where A_c is the carrier amplitude, f_c is the carrier frequency, f_m is the modulating frequency, and $\beta \ll 1$ is the modulation index. Which of the following statements is correct?

- (A) The minimum value of the signal envelope is $A_c \sqrt{1 - \beta^2}$
 (B) The maximum value of the signal envelope is $A_c \sqrt{1 + \beta^2}$
 (C) The total average power of the FM is $\frac{(1+\beta^2)A_c^2}{2}$
 (D) The total average power of the FM is $\frac{(1+\beta^2)A_c^2}{4}$
 (E) None of the above

6. (5%) Consider a signal

$$x(t) = \begin{cases} 9 - t^2, & |t| \leq 3 \\ 0, & \text{otherwise} \end{cases}$$

with its Fourier transform $X(f)$. Which of the following statements is wrong?

- (A) The imaginary part of $X(f)$ is zero.
 (B) The value of $\int_{-\infty}^{\infty} X(f) df$ is 9.
 (C) The value of $X(0)$ is 36.
 (D) The value of $\int_{-\infty}^{\infty} |X(f)|^2 df$ is 324.
 (E) The value of $\int_{-\infty}^{\infty} f \cdot X(f) df$ is 0.

7. (5%) The signals $x_i(t)$ undergo sampling with sampling period $T_s = 0.02$ second. Which of the following signals can be recovered perfectly from the sampled signal.

$$\begin{aligned} x_1(t) &= \frac{\sin(40\pi t)}{\pi t}, \\ x_2(t) &= \frac{\sin(40\pi t)}{\pi t} \cdot \frac{\sin(20\pi t)}{\pi t}, \\ x_3(t) &= t x_2(t), \\ x_4(t) &= x_1(t) \cdot \cos(20\pi t), \\ x_5(t) &= \frac{d}{dt} x_1(t), \end{aligned}$$

- (A) $x_1(t), x_3(t)$.
 (B) $x_1(t), x_5(t)$
 (C) $x_2(t), x_4(t)$.
 (D) $x_1(t), x_3(t), x_5(t)$.
 (E) $x_3(t), x_4(t), x_5(t)$.

8. (5%) Let $X(t) = A \cdot \cos(2\pi f_c t + \Theta)$ be a real-valued random process, where A is a constant, Θ is a random variable uniformly distributed between 0 and 2π . Which of the following is wrong.

- (A) $X(t)$ is wide-sense stationary (WSS).
 (B) Mean value of $X(t)$ is zero
 (C) Autocorrelation function of $X(t)$ is $R_X(\tau) = \frac{A^2}{2} \cos(2\pi f_c \tau)$
 (D) Power spectral density function of $X(t)$ is $S_X(f) = \frac{A^2}{4} [\delta(f - f_c) + \delta(f + f_c)]$
 (E) Average power of $X(t)$ is A^2

國立中山大學 115 學年度碩士班考試入學招生考試試題

科目名稱：通訊理論【電機系碩士班戊組選考、通訊所碩士班甲組、乙組選考、電波聯合碩士班選考】題號：437002

※本科目依簡章規定「可以」使用計算機（廠牌、功能不拘）（混合題）

共 4 頁 第 3 頁

9. (5%) Consider an amplitude-modulated signal expressed by

$$s(t) = A_c(1 + k_a m(t)) \cos(2\pi f_c t).$$

Which of the following is wrong.

- (A) The amplitude sensitivity k_a can be any positive real number
- (B) The message $m(t)$ can be recovered from an envelop detector
- (C) We may apply DSB-SC (double sideband- suppress subcarrier) to reduce transmission power
- (D) We may apply SSB (single sideband) scheme to reduce required transmission bandwidth
- (E) The transmission bandwidth of VSB(vestigial-sideband) is between those of the SSB and DSB-SC.

10. (5%) Consider an Frequency-modulated signal expressed by

$$s(t) = A_c \cos \left[2\pi f_c t + 2\pi k_f \int_0^t m(\tau) d\tau \right],$$

where the message $m(t)$ has the maximum amplitude of A_m and the highest frequency F_m . Which of the following is wrong.

- (A) The instantaneous frequency of $s(t)$ is $f_c + k_f m(t)$
- (B) The transmission power of is $A_c^2/2$
- (C) If we connect an FM modulator with an integrator, we can generate a phase-modulated signal
- (D) The maximum frequency deviation is $k_f A_m$
- (E) The transmission bandwidth of $s(t)$ is approximately $2k_f A_m + 2F_m$

二、問答計算題：

1. (10%) Consider the following baseband signal $g(t)$:

$$g(t) = \begin{cases} t/2, & 0 \leq t < T \\ 0, & \text{otherwise} \end{cases}$$

- (A)(5%) Determine the impulse response of a filter $h(t)$ matched to the signal.
- (B)(5%) Plot the matched filter output $g_0(t) = g(t) * h(t)$ in the absence of noise.

2. (15%) Consider the frequency demodulation scheme shown as Fig.1, where the incoming FM signal is given by

$$s(t) = A_c \cos[2\pi f_c t + \beta \sin(2\pi f_m t)].$$

The delay line produces a delayed signal $s(t - T)$, and leads to a phase-shift of $\pi/2$ radians at the carrier frequency f_c , i.e., $2\pi f_c T = \pi/2$. Assume that $\beta < 1$ and T is sufficiently small, s.t.

$$\begin{aligned} \cos(2\pi f_m T) &\approx 1 \\ \sin(2\pi f_m T) &\approx 2\pi f_m T. \end{aligned}$$

Find the output signal of the demodulator.

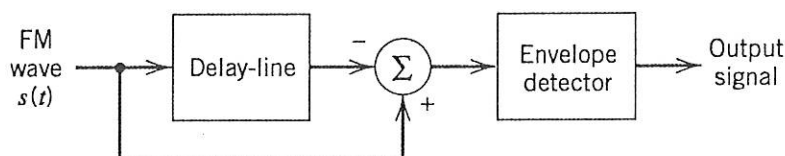

Fig.1 Frequency demodulator

國立中山大學 115 學年度碩士班考試入學招生考試試題

科目名稱：通訊理論【電機系碩士班戊組選考、通訊所碩士班甲組、乙組選考、電波聯合碩士班選考】題號：437002

※本科目依簡章規定「可以」使用計算機（廠牌、功能不拘）（混合題） 共 4 頁第 4 頁

3. (10%) Consider antipodal signaling with amplitude imbalance. That is, a logic-1 symbol is transmitted as a rectangular pulse of amplitude A_1 , and duration T , and a logic-0 symbol is transmitted as a rectangular pulse of amplitude $-A_2$, where $A_1 \geq A_2 > 0$. The receiver employs a fixed decision threshold at zero. Define the ratio $\rho = A_2/A_1$, and note that the average signal energy, for equally likely 1s and 0s, is

$$E = \frac{A_1^2 + A_2^2}{2} T.$$

The channel noise is additive white Gaussian noise (AWGN) with two-sided power spectral density $N_0/2$. Show that the resulting probability of bit error can be expressed as

$$P_e = \frac{1}{2} Q\left(\sqrt{\frac{2}{1 + \rho^2} \frac{2E}{N_0}}\right) + \frac{1}{2} Q\left(\sqrt{\frac{2\rho^2}{1 + \rho^2} \frac{2E}{N_0}}\right).$$

4. (15%) Consider a real-valued message signal $m(t)$ whose spectrum is nonzero over the frequency range 200 Hz to 3 kHz, as illustrated in Fig. 2. This message is SSB modulated to produce the transmitted signal

$$s(t) = A_c m(t) \cos(2\pi f_c t) + A_c \hat{m}(t) \sin(2\pi f_c t),$$

Where $\hat{m}(t)$ denotes the Hilbert transform of $m(t)$. At the receiver, $s(t)$ is demodulated using a carrier of the form $\cos(2\pi(f_c + \Delta f)t)$. Assume that the lowpass filter is ideal with unity gain and extends over $[-4k, 4k]$ Hz, and $f_c = 20$ kHz.

- (A) (5%) Derive the expression for the demodulated signal at the output of the lowpass filter.
- (B) (5%) Plot the spectrum of the demodulated signal when $\Delta f = 20$ Hz.
- (C) (5%) Plot the spectrum of the demodulated signal when $\Delta f = -10$ Hz.

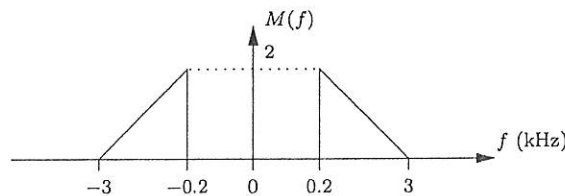

Fig.2 Message Spectrum

國立中山大學 115 學年度 碩士班考試入學招生考試試題

科目名稱：工程數學甲【電機系碩士班戊組選考、庚組、通訊所碩士班乙組選考、電波聯合碩士班選考】

—作答注意事項—

考試時間：100 分鐘

- 考試開始鈴響前不得翻閱試題，並不得書寫、劃記、作答。請先檢查答案卷（卡）之應考證號碼、桌角號碼、應試科目是否正確，如有不同立即請監試人員處理。
- 答案卷限用藍、黑色筆(含鉛筆)書寫、繪圖或標示，可攜帶橡皮擦、無色透明無文字墊板、尺規、修正液（帶）、手錶(未附計算器者)。每人每節限使用一份答案卷，請衡酌作答。
- 答案卡請以 2B 鉛筆劃記，不可使用修正液（帶）塗改，未使用 2B 鉛筆、劃記太輕或污損致光學閱讀機無法辨識答案者，後果由考生自負。
- 答案卷（卡）應保持清潔完整，不得折疊、破壞或塗改應考證號碼及條碼，亦不得書寫考生姓名、應考證號碼或與答案無關之任何文字或符號。
- 可否使用計算機請依試題資訊內標註為準，如「可以」使用，廠牌、功能不拘，唯不得攜帶書籍、紙張（應考證不得做計算紙書寫）、具有通訊、記憶、傳輸或收發等功能之相關電子產品或其他有礙試場安寧、考試公平之各類器材入場。
- 試題及答案卷（卡）請務必繳回，未繳回者該科成績以零分計算。
- 試題採雙面列印，考生應注意試題頁數確實作答。
- 違規者依本校招生考試試場規則及違規處理辦法處理。

國立中山大學 115 學年度碩士班考試入學招生考試試題

科目名稱：工程數學甲【電機系碩士班戊組選考、庚組、通訊所碩士班乙組選考、電波聯合碩士班選考】題號：431002

※本科目依簡章規定「可以」使用計算機（廠牌、功能不拘）（選擇題） 共 5 頁第 1 頁

下面 1-10 題為複選題，每題 5 分，總分 50 分。每題有五個選項，其中至少有一個是正確答案。答錯 1 個選項者，得 3 分，答錯 2 個選項者，得 1 分，答錯多於 2 個選項或未作答者，該題以零分計算。

1. Let $\mathbf{a}_1, \mathbf{a}_2, \mathbf{a}_3, \mathbf{a}_4, \mathbf{d} \in \mathbb{R}^n$. Define the matrices

$$\mathbf{B} = [\mathbf{a}_1, \mathbf{a}_2, \mathbf{a}_3] \in \mathbb{R}^{n \times 3}, \quad \mathbf{C} = [\mathbf{a}_1, \mathbf{a}_2, \mathbf{a}_3, \mathbf{a}_4] \in \mathbb{R}^{n \times 4}.$$

Assume that the linear system $\mathbf{B}\mathbf{x} = \mathbf{d}$ has no solution for $\mathbf{x} \in \mathbb{R}^3$, and the linear system $\mathbf{C}\mathbf{y} = \mathbf{d}$ has at least one solution for $\mathbf{y} \in \mathbb{R}^4$. Let $[\mathbf{B}, \mathbf{d}] = [\mathbf{a}_1, \mathbf{a}_2, \mathbf{a}_3, \mathbf{d}] \in \mathbb{R}^{n \times 4}$. Which of the following statements are true? (Select all that apply.)

- (A) The set $\{\mathbf{a}_4, \mathbf{d}\}$ is linearly dependent.
- (B) The set $\{\mathbf{a}_1, \mathbf{a}_2, \mathbf{a}_3, \mathbf{d}\}$ is linearly dependent.
- (C) The set $\{\mathbf{a}_1, \mathbf{a}_2, \mathbf{a}_3, \mathbf{a}_4\}$ is linearly independent.
- (D) $\text{rank}(\mathbf{C}) > \text{rank}(\mathbf{B})$.
- (E) $\text{rank}(\mathbf{C}) = \text{rank}([\mathbf{B}, \mathbf{d}])$.

2. Let $\mathbf{A} \in \mathbb{R}^{m \times n}$. For any matrix \mathbf{M} , let $R(\mathbf{M})$ denote the column space and $N(\mathbf{M})$ denote the null space. Which of the following statements are true? (Select all that apply.)

- (A) If $\mathbf{y} \in R(\mathbf{A}\mathbf{A}^T)$ and $\mathbf{y} \neq \mathbf{0}$, then $\mathbf{A}^T\mathbf{y} \neq \mathbf{0}$.
- (B) If $\mathbf{y} \in R(\mathbf{A})$, then $\mathbf{A}^T\mathbf{y} = \mathbf{0}$.
- (C) If $m = n$, then $R(\mathbf{A}) = R(\mathbf{A}^T)$.
- (D) If $m = n$, then $N(\mathbf{A}) = N(\mathbf{A}^T)$.
- (E) If $\mathbf{x} \in \mathbb{R}^n$ and $\mathbf{A}\mathbf{x} \neq \mathbf{0}$, then $\mathbf{x} \in R(\mathbf{A}^T)$.

3. Let $\mathbf{A} \in \mathbb{R}^{m \times n}$, $\mathbf{B} \in \mathbb{R}^{m \times k}$, and $\mathbf{C} \in \mathbb{R}^{k \times n}$ such that $\mathbf{A} = \mathbf{B}\mathbf{C}$. For any matrix \mathbf{M} , let $R(\mathbf{M})$ denote the column space and $N(\mathbf{M})$ denote the null space. Which of the following statements are true? (Select all that apply.)

- (A) $R(\mathbf{B})$ is a subset of $R(\mathbf{A})$.
- (B) $N(\mathbf{A})$ is a subset of $N(\mathbf{C})$.
- (C) $k \geq \text{rank}(\mathbf{A})$.
- (D) If $k > \text{rank}(\mathbf{A})$, then $\text{rank}(\mathbf{B}) = \text{rank}(\mathbf{C})$.
- (E) If $k = \text{rank}(\mathbf{A})$, then $\text{rank}(\mathbf{A}) = \text{rank}(\mathbf{B})$.

4. Let

$$\mathbf{A} = \begin{bmatrix} 3 & 0 & 3 & 0 & 3 \\ 0 & 2 & 0 & 2 & 0 \\ 3 & 0 & 3 & 0 & 3 \\ 0 & 2 & 0 & 2 & 0 \\ 3 & 0 & 3 & 0 & 3 \end{bmatrix}.$$

Which of the following statements are true? (Select all that apply.)

- (A) \mathbf{A} is diagonalizable (over \mathbb{R}).
- (B) $\text{rank}(\mathbf{A}) = 2$.
- (C) 2 is an eigenvalue of \mathbf{A} .
- (D) 3 is an eigenvalue of \mathbf{A} .
- (E) The number of positive eigenvalues of \mathbf{A} is 2.

國立中山大學 115 學年度碩士班考試入學招生考試試題

科目名稱：工程數學甲【電機系碩士班戊組選考、庚組、通訊所碩士班乙組選考、電波聯合碩士班選考】題號：431002

※本科目依簡章規定「可以」使用計算機（廠牌、功能不拘）（選擇題）

共 5 頁第 2 頁

5. Let

$$\mathbf{v}_1 = \begin{bmatrix} 1 \\ 0 \\ 1 \end{bmatrix}, \mathbf{v}_2 = \begin{bmatrix} 1 \\ 0 \\ -1 \end{bmatrix}, \mathbf{x} = \begin{bmatrix} 2 \\ 3 \\ 1 \end{bmatrix},$$

and define the subspace $W = \text{span}\{\mathbf{v}_1, \mathbf{v}_2\} \subset \mathbb{R}^3$. Let \mathbf{p} be the orthogonal projection of \mathbf{x} onto W . For any vector \mathbf{u} , let $\|\mathbf{u}\|$ denote the Euclidean norm: $\|\mathbf{u}\| = \sqrt{\mathbf{u}^T \mathbf{u}}$. Which of the following statements are true? (Select all that apply.)

- (A) $\|\mathbf{p}\| = 2$.
- (B) $\|\mathbf{x} - \mathbf{p}\| = 3$.
- (C) $\mathbf{w}^T(\mathbf{x} - \mathbf{p}) = 0$ for every $\mathbf{w} \in W$.
- (D) $\mathbf{x} - \mathbf{p} \in W$.
- (E) \mathbf{p} is orthogonal to \mathbf{v}_1 .

6. Let

$$\mathbf{b}_1 = \begin{bmatrix} 1 \\ 1 \\ 0 \end{bmatrix}, \mathbf{b}_2 = \begin{bmatrix} 1 \\ -1 \\ 0 \end{bmatrix}, \mathbf{b}_3 = \begin{bmatrix} 0 \\ 0 \\ 1 \end{bmatrix}, \mathbf{x} = \begin{bmatrix} 2 \\ 0 \\ 3 \end{bmatrix}.$$

Define a linear transformation $L: \mathbb{R}^3 \rightarrow \mathbb{R}^3$ satisfying

$$L(\mathbf{b}_1) = 2\mathbf{b}_1, L(\mathbf{b}_2) = \mathbf{b}_2, L(\mathbf{b}_3) = -\mathbf{b}_3.$$

Let $L^5(\mathbf{x}) = L(L(L(L(L(\mathbf{x})))))$. Suppose that, in standard coordinates (with respect to the standard basis of \mathbb{R}^3), $L^5(\mathbf{x}) = [y_1, y_2, y_3]^T \in \mathbb{R}^3$. Let \mathbf{A} be the matrix representation of L with respect to the ordered basis $\{\mathbf{b}_1, \mathbf{b}_2, \mathbf{b}_3\}$. Which of the following statements are true? (Select all that apply.)

- (A) $y_1 = 33$.
- (B) $y_2 = 31$.
- (C) $y_3 = -3$.
- (D) $\det(\mathbf{A}) = -2$.
- (E) $\text{rank}(\mathbf{A}) = 2$.

7. Consider the surface $z = x^2 + y^2$ at the point $P(2, -2, 8)$. Which of the following is/are correct? Assume t below is a scalar. The $\mathbf{i}, \mathbf{j}, \mathbf{k}$ are unit vectors along the x -, y - and z -axis, respectively.

- (A) The gradient vector is $2x\mathbf{i} + 2y\mathbf{j} - \mathbf{k}$.
- (B) The tangent plane equals $4x - 4y - z = 8$.
- (C) The normal vector to the surface at P is $4\mathbf{i} - 4\mathbf{j} - 8\mathbf{k}$.
- (D) The greatest rate of increase in the direction of the normal vector is $\sqrt{32}$.
- (E) The parametric equations of the normal line are $x = 2 + 4t, y = -2 - 4t, z = 8 - t$.

8. Consider a space curve defined by the intersection of the surface $z = \cot^{-1}(x/y)$ and the cylinder $x^2 + y^2 = 1$. Assume \cot^{-1} denotes the principal value with the range $(0, \pi)$ and restrict to the branch where $y > 0$. The $\mathbf{i}, \mathbf{j}, \mathbf{k}$ are unit vectors along the x -, y - and z -axis, respectively. Which of the following is/are correct?

- (A) The arc length between $(1, 0, 0)$ and $(1, 0, \pi/2)$ is $\sqrt{2}\pi$.
- (B) The curvature is 2.
- (C) The radius of curvature is 2.
- (D) The unit tangent vector at $(0, 1, \pi/2)$ is $(-\mathbf{i} + \mathbf{k})/\sqrt{2}$.
- (E) The unit normal vector at $(0, 1, \pi/2)$ is \mathbf{j} .

國立中山大學 115 學年度碩士班考試入學招生考試試題

科目名稱：工程數學甲【電機系碩士班戊組選考、庚組、通訊所碩士班乙組選考、電波聯合碩士班選考】題號：431002

※本科目依簡章規定「可以」使用計算機（廠牌、功能不拘）（選擇題）

共 5 頁第 3 頁

9. Find a solution $u(x, y)$ of the differential equation (DE) $xu_{xy} + 2yu = 0$. Assume $x > 0$. The c and k below are constants, and A, B, E and F are integers. Which of the following is/are INCORRECT?
- (A) $u = cx^{Ak}e^{(By^E)/(Fk)}$, where $A + B = 0$
(B) $u = cx^{Ak}e^{(By^E)/(Fk)}$, where $E + F = 3$
(C) This DE is parabolic.
(D) This DE is elliptic.
(E) This DE is homogeneous.
10. Consider the differential equation (DE) $y' = y^2 - 3y + 2$. Which of the following is/are correct?
- (A) There is an attractor.
(B) $y(x) = 2$ is a singular solution.
(C) $y(x) = (ce^x - 2)/(ce^x + 1)$ is a one-parameter family of solutions, where c is an arbitrary constant.
(D) Provided $y(0) = -1$, the largest interval is $[0, \infty)$.
(E) Given $y(0) = 4$, there exists an interval centered at 0 on which the DE has a unique solution.

下面 11-15 題為單選題，總分 20 分。每題答對 4 分，答錯或未作答者以 0 分計。

For the following problems, let $j = \sqrt{-1}$ denote the imaginary unit.

11. If $z = 3 - 4j$, what is $|z|$?
- (A) 1
(B) 5
(C) 7
(D) $\sqrt{7}$
12. The function $f(z) = \bar{z}$ is:
- (A) Analytic everywhere
(B) Analytic only at $z = 0$
(C) Not analytic anywhere
(D) Entire
13. Let $f(z) = z^2$, find $f'(1 + j)$.
- (A) $1 + j$
(B) $2 + 2j$
(C) $2 - 2j$
(D) $4j$
14. Let $z = x + jy$. Which of the following functions satisfies the Cauchy–Riemann equations?
- (A) $f(z) = x^2 + y^2$
(B) $f(z) = x^2 - y^2 + j(2xy)$
(C) $f(z) = x^2 + jy^2$
(D) $f(z) = |z|^2$

國立中山大學 115 學年度碩士班考試入學招生考試試題

科目名稱：工程數學甲【電機系碩士班戊組選考、庚組、通訊所碩士班乙組選考、電波聯合碩士班選考】題號：431002

※本科目依簡章規定「可以」使用計算機（廠牌、功能不拘）（選擇題）

共 5 頁第 4 頁

15. Evaluate

$$\oint_{|z|=2} \frac{1}{z} dz.$$

- (A) 0
(B) 1
(C) 2π
(D) $2\pi j$

下面 16-21 題為單選題，總分 30 分。每題答對 5 分，答錯或未作答者以 0 分計。

16. If $f(t) = \cos(3t) + 3t \sin(3t)$, then its Laplace Transform is given by?

- (A) $\frac{s+3}{s-3}$ (B) $\frac{27}{(s^2+9)^2}$ (C) $\frac{s(s^2+27)}{(s^2+9)^2}$ (D) Does not exist

17. Consider three continuous-time periodic signals whose Fourier series representations are as follows:

$$x_1(t) = \sum_{k=0}^{100} \left(\frac{1}{2}\right)^k e^{jk\frac{2\pi}{50}t}, x_2(t) = \sum_{k=-100}^{100} \cos(k\pi) e^{jk\frac{2\pi}{50}t}, x_3(t) = \sum_{k=-100}^{100} j \sin\left(\frac{k\pi}{2}\right) e^{jk\frac{2\pi}{50}t}.$$

Which of the three signal is/are even?

- (A) $x_1(t)$
(B) $x_2(t)$
(C) $x_3(t)$
(D) $x_2(t)$ and $x_3(t)$

18. Let $x(t)$ be a periodic signal with Fourier series coefficients defined by

$$a_k = \begin{cases} 2, & k = 0 \\ j\left(\frac{1}{2}\right)^{|k|}, & k \neq 0 \end{cases}$$

Which of the following statements is **true**?

- (A) $x(t)$ is real.
(B) $x(t)$ is even.
(C) $\frac{dx(t)}{dt}$ is even.
(D) None of the above.

19. The Fourier Transform of $e^{-|t|}$ is $\frac{2}{1+\omega^2}$. Then, what is the Fourier Transform of $e^{-2|t|}$?

- (A) $\frac{4}{4+\omega^2}$ (B) $\frac{2}{4+\omega^2}$ (C) $\frac{2}{2+\omega^2}$ (D) $\frac{4}{2+\omega^2}$

國立中山大學 115 學年度碩士班考試入學招生考試試題

科目名稱：工程數學甲【電機系碩士班戊組選考、庚組、通訊所碩士班乙組選考、電波聯合碩士班選考】題號：431002

※本科目依簡章規定「可以」使用計算機（廠牌、功能不拘）（選擇題）

共 5 頁第 5 頁

20. For each of the following Fourier transforms, use Fourier transform properties to determine which of the corresponding time-domain signal is purely imaginary and odd. Do this without evaluating the inverse of any of the given transforms.

(A) $X(j\omega) = u(\omega) - u(\omega - 2)$

(B) $X(j\omega) = \cos(2\omega) \sin\left(\frac{\omega}{2}\right)$

(C) $X(j\omega) = A(\omega)e^{jB(\omega)}$, where $A(\omega) = (\sin 2\omega)/\omega$ and $B(\omega) = 2\omega + \frac{\pi}{2}$

(D) $X(j\omega) = \sum_{k=-\infty}^{\infty} \left(\frac{1}{2}\right)^{|k|} \delta\left(\omega - \frac{k\pi}{4}\right)$

21. Determine the inverse Laplace transform $x(t) = \mathcal{L}^{-1}\{X(s)\}$ for $t \geq 0$:

$$X(s) = \frac{s - 1}{s^2 + 3s + 2}.$$

(A) $x(t) = (3e^{-2t} - 2e^{-t})u(t)$

(B) $x(t) = (2e^{-t} - 3e^{-2t})u(t)$

(C) $x(t) = (3e^{-t} - 2e^{-2t})u(t)$

(D) $x(t) = (3e^{-2t} + 2e^{-t})u(t)$

國立中山大學 115 學年度 碩士班考試入學招生考試試題

科目名稱：電磁學【電機系碩士班戊組、通訊所碩士班乙組、電波聯合碩士班】

—作答注意事項—

考試時間：100 分鐘

- 考試開始鈴響前不得翻閱試題，並不得書寫、劃記、作答。請先檢查答案卷（卡）之應考證號碼、桌角號碼、應試科目是否正確，如有不同立即請監試人員處理。
- 答案卷限用藍、黑色筆(含鉛筆)書寫、繪圖或標示，可攜帶橡皮擦、無色透明無文字墊板、尺規、修正液（帶）、手錶(未附計算器者)。每人每節限使用一份答案卷，請衡酌作答。
- 答案卡請以 2B 鉛筆劃記，不可使用修正液（帶）塗改，未使用 2B 鉛筆、劃記太輕或污損致光學閱讀機無法辨識答案者，後果由考生自負。
- 答案卷（卡）應保持清潔完整，不得折疊、破壞或塗改應考證號碼及條碼，亦不得書寫考生姓名、應考證號碼或與答案無關之任何文字或符號。
- 可否使用計算機請依試題資訊內標註為準，如「可以」使用，廠牌、功能不拘，唯不得攜帶書籍、紙張（應考證不得做計算紙書寫）、具有通訊、記憶、傳輸或收發等功能之相關電子產品或其他有礙試場安寧、考試公平之各類器材入場。
- 試題及答案卷（卡）請務必繳回，未繳回者該科成績以零分計算。
- 試題採雙面列印，考生應注意試題頁數確實作答。
- 違規者依本校招生考試試場規則及違規處理辦法處理。

國立中山大學 115 學年度碩士班考試入學招生考試試題

科目名稱：電磁學【電機系碩士班戊組、通訊所碩士班乙組、電波聯合碩士班】題號：482004

※本科目依簡章規定「可以」使用計算機（廠牌、功能不拘）（問答申論題） 共 1 頁第 1 頁

1. (25%) In a charge-free region, the electric field intensity is $\mathbf{E} = (x + 3y - k_1z)\mathbf{a}_x + (k_2x + 5z)\mathbf{a}_y + (2x - k_3y + k_4z)\mathbf{a}_z$. Please determine the values of the constants k_1, k_2, k_3 , and k_4 .
2. (25%) A planar rectangular loop with length a and width b carries a direct current I . Find the magnetic flux density at the center of the rectangle.
3. (10%) Please describe in detail the boundary conditions of electromagnetic fields at the interface between two dielectric media.
4. (15%) In seawater, a uniform plane wave propagates in the $+z$ direction. At $z = 0$, the electric field intensity is given by $\mathbf{E} = \mathbf{a}_x 100 \cos(10^7 \pi t)$ (V/m). The relative permittivity ϵ_r of seawater is 72, the relative permeability μ_r is 1, and the conductivity σ is 4 S/m. Please derive in detail the polarization of this uniform plane wave, its phase velocity, and the instantaneous expression of the magnetic field intensity at $z = 0.8$ m.
5. (10%) As shown in Fig. 1,

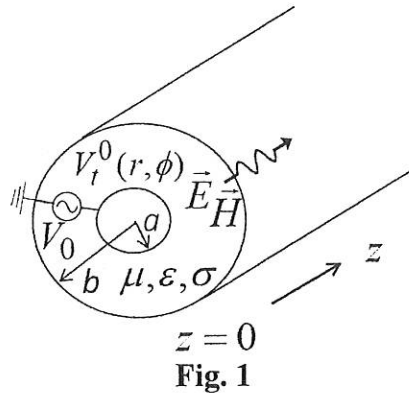

Consider a coaxial cable that operates in the TEM mode. The inner conductor has radius a , and the outer conductor has radius b ; the thickness of both conductors can be neglected. The region between the inner and outer conductors is filled with a dielectric material with permittivity ϵ and permeability μ . Please calculate the surface current density on the two conductors and the characteristic impedance of this coaxial cable, respectively.

6. (15%) Consider a circuit that includes a signal generator with an internal resistance of 50Ω , producing a sinusoidal voltage of 10 V at 300 MHz. The signal generator is connected to a transmission line of length 2 m and characteristic impedance 50Ω . The end of the transmission line is terminated with a load impedance of $(30 - 40j) \Omega$. Please derive in detail the reflection coefficient at the load end of the transmission line and the expression for the voltage along the transmission line. In addition, to maximize the average power delivered to the load, what should the load impedance be set to?